

The Story of Titanic

has fascinated audiences since long before that fateful April day in 1912 when it disappeared beneath the waves. Its construction, representing the cutting edge of the time, generated a media blitz that promoted the notion that the ship was “unsinkable.” The human drama of its maiden voyage resulted in numerous books and movies.

“Titanic Science” tells the story of how the cutting edge of science and technology in 1912 and the present have come together to give new insights into the tragedy. It’s a story about scientific investigation and the search for answers.

The purpose of this guide is to explore the story of *Titanic* primarily from the scientific point of view. The emphasis is on hands-on investigation for students. How could 66,000 tons of steel float in the first place? How could an iceberg sink the “practically unsinkable”? What modern scientific techniques can answer these and other questions?

All activities are coded to the appropriate National Science Standards and National Social Studies Standards. Several activities promote open-ended problem solving. Relevant background information is provided for each activity, along with additional resources such as books, websites and videos that expand on the activity.

For more information about the exhibition, check out the *Titanic Science* Web site at www.titanicscience.com

Acknowledgements

Writer:

Jeannine Finton

Graphic Design:

Alton Creative

Evaluation:

Randi Korn &
Associates

Content Reviewers:

John Eaton,
Titanic Historian
Charles Haas,
Titanic Historian
Dr. D. Roy Cullimore,
Microbiologist
Dr. Timothy Foecke,
Material Scientist

The Maryland Science Center acknowledges the generous assistance of the following during the design and development of Titanic Science:

Partners:



Video Footage:



Major Funding:



Contents

The Great Ship: History and Shipbuilding Principles	3
Sinkers and Floaters	4
Buoyancy	5
Displacement	6
Design a Ship	7
Watertight Bulkheads	8
What Sank the <i>Titanic</i>?	10
Making an Iceberg	11
Plotting Icebergs and Locations	12
Calculating Iceberg Frequency	15
Iceberg Impact	17
Water Pressure	19
Rivet Failure	21
Create Your Own Photomosaic	23
Photomosaic of <i>Titanic</i>	24
Communication	29
What We Have Here is a Failure to Communicate	29
Wireless Radio and <i>Titanic</i>	32
Wireless Radio	34
Survivor Stories	36
Survivors’ Testimonies	37
Estimating the Angles	38
Testing Eyewitness Memory	39
Could More Have Been Saved?	40
The Fate of <i>Titanic</i> and its Artifacts	43
Rust in the Classroom	43
Rust on the <i>Titanic</i>	44
Artifact Conservation	46

National Educational Standards

	SCIENCE	SCIENCE as Inquiry	Physical Science	Earth and Space Science	Life Science	Science and Technology	Science in Personal and Social Perspectives	History and Nature of Science	SOCIAL STUDIES	Time, Continuity and Change	People, Places and Environments
Activities											
The Great Ship											
Sinkers and Floaters		●	●								
Buoyancy		●	●	●							
Displacement		●	●	●							
Design a Ship		●	●	●		●					
Watertight Bulkheads		●	●	●		●					
What Sank the Titanic?											
Making an Iceberg			●	●							
Plotting Icebergs and Locations										●	●
Calculating Iceberg Frequency				●			●			●	●
Water Pressure			●	●							
Rivet Failure		●	●			●		●			
Create Your Own Photomosaic						●					●
Photomosaic of Titanic						●					●
Communication											
What We Have Here is a Failure to Communicate											
Wireless Radio		●	●			●					
Survivor Stories											
Survivors' Testimonies					●					●	
Estimating the Angles		●			●					●	
Testing Eyewitness Memory		●			●					●	
Could More Have Been Saved?		●				●	●			●	●
The Fate of Titanic											
Rust in the Classroom			●								
Rust on the Titanic		●	●		●						
Artifact Conservation		●	●			●				●	

The Great Ship

HISTORY AND SHIPBUILDING PRINCIPLES

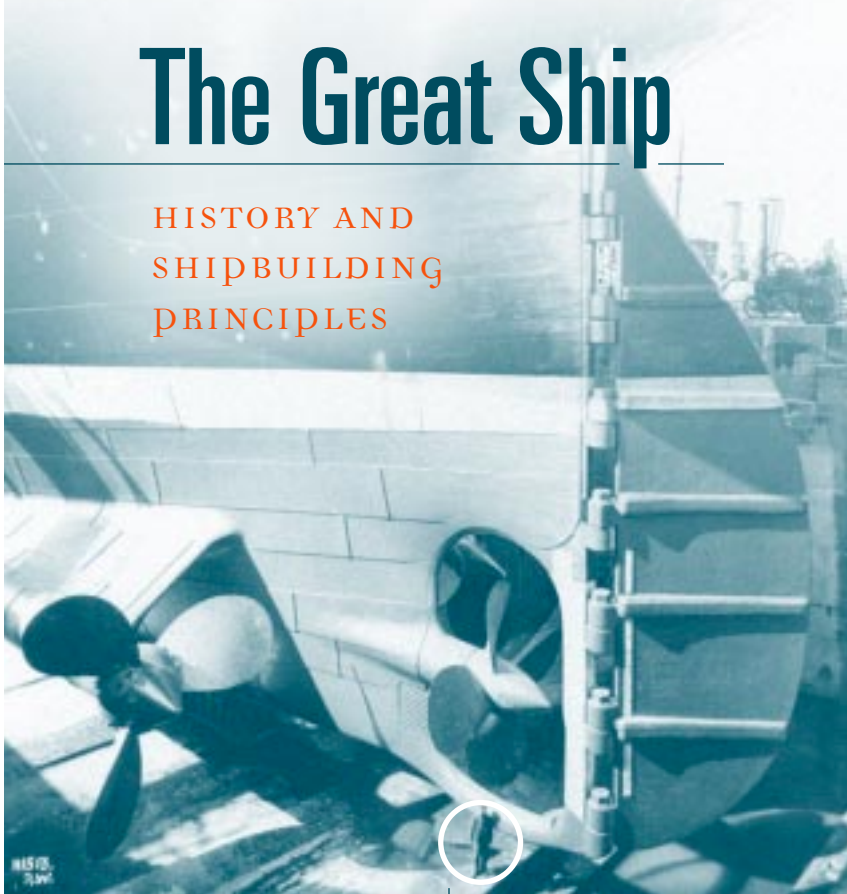

Introduction to Titanic

Titanic and her sister ship *Olympic*, owned by the White Star Line, were designed to set new standards of luxury for trans-Atlantic travel. They weren't intended to be the fastest, but they were to be the largest, able to accommodate more freight and passengers than their faster competitors. They could guarantee a week's crossing in spectacular conditions. The first class accommodations included elaborate suites decorated in a variety of styles. First-class passengers could also enjoy a gymnasium, swimming pool, squash racket courts and Turkish bath. Second class accommodations on *Titanic* were better than first class on many other ships. Third class



Above: Photograph of *Titanic's* massive rudder and propellers. Note the relative size of the man standing beneath them.

passengers, most of them emigrants, would find the accommodations more comfortable and the food more plentiful than anything they had previously known in their lives. In addition to carrying passengers, *Titanic* was also designed to carry cargo.

The Harland and Wolff shipyard in Belfast, Ireland, handled actual construction. Harland and Wolff had built ships for the White Star Line since 1870. The ships were constructed on a cost-plus basis. Instead of providing a construction budget up front, the White Star Line executives would tell Harland and Wolff

Titanic Statistics

- The largest movable man-made object ever made (at that time)
- Passenger capacity: 2,435
- Total crew: 885
- Total passengers and crew: 3,320
- Displacement/weight: 66,000 tons of water
- Length: 882.5 feet
- Width: 93 feet
- Height from bottom of ship (keel) to top of funnels: 175 feet
- Draught (depth to which a vessel is immersed): 34 feet 7 inches
- Cruising speed: 22.5 knots (miles per hour = knots multiplied by 1.152)
- Combined weight of 3 anchors: 31 tons
- Size of propellers: The 2 outer propellers had a diameter of 23 feet. The center propeller had a diameter of 17 feet.
- Rudder: 78 feet high, weight 101 tons
- A total of 3 million rivets (1,200 tons) held the ship's steel hull together
- Engines: two four-cylinder steam reciprocating engines and one low-pressure turbine engine. Total horsepower was 46,000
- 159 furnaces (stoked by hand) burned coal to operate 29 boilers



what they wanted and the shipyard built it. Approximately 14,000 workers were used to construct *Titanic*. At the end, Harland and Wolff provided White Star with a bill for their costs, plus an additional percentage for their profit. No expense was spared. *Titanic*, when fully equipped, cost about \$7,500,000. (In 1997 it was estimated that it would cost over \$400 million to build today.)

Construction on *Olympic* began on December 16, 1908 followed by *Titanic* on March 31, 1909. *Titanic* was launched on May 31, 1911. At this point it was only

an empty shell. Construction continued as the machinery was added, funnels erected, plumbing installed, etc. *Titanic* first went to sea on April 2, 1912 for its sea trials. An inspector of the British Board of Trade came along to make certain that the ship was seaworthy. By 7 pm, the inspector signed the certificate that stated that the ship met Board of Trade approval and he and others who were not to travel with *Titanic* returned to Belfast. The ship turned and headed to Southampton, England, where it docked on April 4, 1912.

In Southampton, *Titanic* received its final provisions for its maiden voyage. Carpets were laid, draperies hung, dishes and tableware arrived. Cargo began arriving, including cases of hosiery, rabbit skins, golf balls, melons, potatoes, champagne, cheeses, mushrooms, ostrich feathers and more. Passengers began arriving Wednesday morning,

April 10. *Titanic* sailed at noon that day, barely a week from its first day at sea.

While legend has it that *Titanic* was a treasure ship, the cargo manifest shows that the cargo was mundane and only worth \$420,000 in 1912. Provisions for the passengers and crew were also loaded, including 75,000 lbs. of fresh meat, 7,000 heads of lettuce, 40 tons of potatoes, 1,500 gallons of milk, 36,000 oranges and 20,000 bottles of beer and stout.

1912 postcard, showing *Titanic* in comparison to some of the largest buildings of the day.



ACTIVITY

Sinkers and Floaters

The National Science Education Standards



Science as Inquiry:

Abilities necessary to do scientific inquiry



Science as Inquiry:

Understanding about scientific inquiry



Physical Science:

Properties of objects and materials

Grade Level:

Early elementary

Objective:

Students will understand that objects can be categorized by their ability to sink/float

Time:

30 minutes

Group Size:

Individual or small group (3-4)

Materials:

A variety of objects such as soap, rocks, leaves, wood, forks, toys, etc. Use your imagination! Note: this activity can be assigned as homework, allowing students to test objects around the house. Dishpan or bathtub
Water

Procedure:

1. Have students test a variety of objects for the ability to sink or float. Students should make lists of “Sinkers”, “Floaters” and “Both”—objects that may do either depending on the circumstances (example—a paper towel).
2. Make a large list on the board to compare the results.

Teacher note: Exactly why an object will float or sink depends on a variety of factors including the weight, density, shape, etc.

Going Further (optional):

1. Ask students to predict whether or not an object will sink or float before testing it.
2. Give students a lump of clay. Under what conditions will it sink? Float? (A lump of clay will sink if it is in a compact shape such as a sphere. It can float if the shape is altered into a bowl.)

ACTIVITY

Buoyancy

The National Science Education Standards

Grade Level:

All

Objective:

Students will understand that objects immersed in water apparently weigh less due to the physical property of buoyancy.

Time:

30 minutes

Group Size:

Small group (3-4)

Materials:

Activity One:

Modeling clay

Activity Two:

Coffee can with lid

String

Pail or bucket large enough to cover the coffee can

Water



Science as Inquiry:

Abilities necessary to do scientific inquiry



Science as Inquiry:

Understanding about scientific inquiry



Physical Science:

Properties of objects and material



Earth and Space Science:

Properties of earth materials

Teacher Background:

Liquids exert an upward force on an immersed or floating object. This upward force is called buoyancy. The larger the surface area of the object, the greater the area for the water to push back on. Ships such as Titanic are made out of steel. Put a lump of steel in the water and it will sink. Spread the same lump out into a boat shape with thin walls and it can float.



Procedure: Activity One

Take a ball of modeling clay and put in some water. What happens? It sinks. Now take the same piece of clay and spread it out into a bowl shape. Put it on the water and it will float. Why? (The buoyant force of the water has more surface area on which to act.)

Procedure: Activity Two:

1. Fill the coffee can with water. Cover it with the lid.
2. Cut a string or cord about 1 yard or 1 meter in length. Double the string for strength and attach it to the can so that it can be held by the loop.
3. Lower the can into a bucket of water. Have students lift it to the surface of the water, noticing how much effort it takes.
4. Have the students lift the can out of the bucket. Does it feel heavier or lighter than when it was in the water (it should feel heavier).

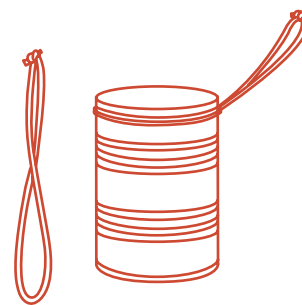

ACTIVITY

Displacement

The National Science Education Standards

Grade Level:

Upper elementary, middle, high

Objective:

Students will understand how displacement is a factor in how ships can float

Time:

30 minutes

Group Size:

Small group

Materials:

Dishpan

Water

Scale

One or two pound coffee can

Objects that float. Note: try to make them as large as possible but still able to fit into the can

**Science as Inquiry:**

Abilities necessary to do scientific inquiry

**Science as Inquiry:**

Understanding about scientific inquiry

**Physical Science:**

Properties of objects and materials

**Earth and Space Science:**

Properties of earth materials

Teacher Background:

Have you ever noticed that when you get into a bathtub that the water level rises? That is because your body displaces (pushes aside) a volume of water. When a ship is in the water, it also displaces a volume of water. If the weight of the ship is less than the weight of the water displaced, then water's buoyant force is capable of keeping the ship afloat. A ship that is launched sinks into the ocean until the weight of the water it displaces is just equal to its own weight. As the ship is loaded, it sinks deeper, displacing more water.

Archimedes' Principle: An object will float if it displaces a volume of water whose weight is the same as its own. An object will sink if it weighs more than the volume of water it displaces.

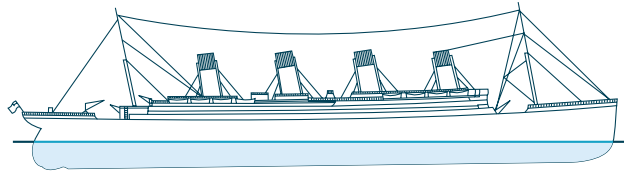

Titanic's displacement was 66,000 tons of water. That's how ship builders refer to the weight of the ship plus fuel and cargo.

Procedure:

1. Weigh a large dishpan and record its weight.
2. Place a coffee can into the dishpan.
3. Fill the can to the very top with water. Wipe the outer surface of the can and dishpan dry.
4. Weigh a large block of wood or other object that floats.
5. Place it in the can. What happens? (The water will be displaced and overflow into the dishpan.)
6. Remove the coffee can and block from the dishpan.
7. Now weigh the dishpan with the water in it. Calculate the weight of the water by subtracting the weight of the dishpan and compare it to the weight of the object. (The two weights should be the same.) Repeat this activity with several other objects that float.

To sum it up, large metal ships float because they weigh the same or less than the water they displace. The trick is to keep it that way!

ACTIVITY

Design a Ship

The National Science Education Standards



Science as Inquiry:

Abilities necessary to do scientific inquiry



Science as Inquiry:

Understanding about scientific inquiry



Physical Science:

Properties of objects and materials



Earth and Space Science:

Properties of earth materials



Science and Technology:

Abilities of technological design



Science and Technology:

Understanding about science and technology

Grade Level:

Upper elementary, middle, high

Objective:

Students will use principles of buoyancy and displacement to design, build and test simple boats to determine which will hold the most cargo

Time:

One class period

Group Size:

Small group (3-4)

Materials

Aluminum foil
Paper cutter or scissors
Marbles or other weights
Ruler
Dishpan(s)
Water

Procedure:

1. Fill dishpans with water and place them at a central testing station. Place a bowl of marbles or other weights at the test station.
2. Cut the aluminum foil into 4" x 6" rectangles. Distribute one per team.
3. Challenge the students to design a boat that can float and hold marbles using only this one piece of aluminum foil. Who can build a boat to hold the largest number of marbles?
3. Test the boats by floating them in the dishpan and adding weights one at a time until it sinks. What boat shape(s) work best?
4. Ask students to compare and contrast each other's boats and identify the factors that make some float better than others. (Boats designed to maximize the amount of surface area for water's buoyant force to work on will do best. An example of this is the flat bottomed barge.)
5. Allow students to refine their boats and retest them.

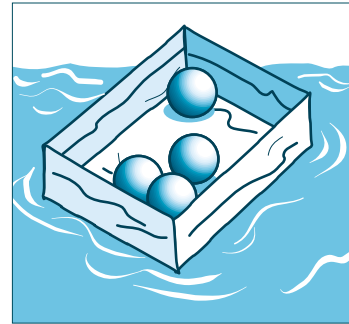

Note: An aluminum boat can easily hold 50 marbles.

Going further (optional):

Ask students to predict how much weight will sink their boats and then test them, using the knowledge gained in the first part of the experience. Hold a competition in which the score is based on how close a boat was to holding the highest weight in its class and the other is based on how closely the student's prediction matched the outcome.

ACTIVITY

Watertight Bulkheads

or HOW TO CARRY SEAWATER AS CARGO

The National Science Education Standards

-  Science as Inquiry:
Abilities necessary to do scientific inquiry
-  Science as Inquiry:
Understanding about scientific inquiry
-  Physical Science:
Properties of objects and materials
-  Earth and Space Science:
Properties of earth materials
-  Science and Technology:
Abilities of technological design
-  Science and Technology:
Understanding about science and technology

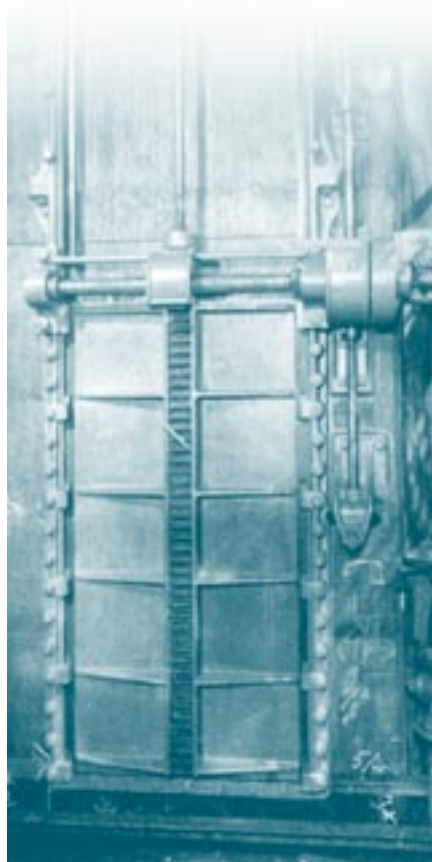

Teacher Background:

One of the advanced safety features of the *Titanic* was the use of “watertight” bulkheads (walls). The lower part of the ship was divided by 15 bulkheads into 16 compartments. In the event of a leak, watertight doors (left) were closed, sealing off the compartment. The ship could float with two of the compartments flooded and would survive with the forward four compartments underwater.

When the *Titanic* was designed, the expectation was that something would make one hole in the side of the ship. Watertight doors would lower, sealing the bulkhead. With waterproof bulkheads extending up through several decks of the ship, a single hole might cause one or two compartments to flood, but the remaining ones would remain dry.

While this would increase the weight of the ship, the ship would still displace enough water to allow it to float. No one expected something that would cause an opening or openings to extend through several compartments at one time.

At the time that the *Titanic* sank, most people believed that the iceberg inflicted a continuous 300-foot-long gash down the side of the ship. Only one expert, a naval architect named Edward Wilding, who worked for Harland and Wolff (the builders of the *Titanic*), believed otherwise. In testimony given in 1912, Wilding asserted that the iceberg damage could have been very small, consisting of a series of small openings, perhaps only three-quarters of an inch wide. He arrived at this conclusion after studying the survivors' testimonies. In his opinion, since the ship flooded unevenly in six compartments, each compartment must have had its own opening to the sea. He held that a gash as long and large as commonly assumed would have sunk the ship in minutes rather than hours. His testimony was ignored by the media and public and people continued to believe that an enormous gaping gash sank the ship.

In a 1996 expedition to the ship, scientists used new sonar technology to see through the 45 feet of mud that covered *Titanic's* bow. Working something like a medical ultrasound, sound waves created an acoustic image of the starboard (right) bow. They found that *Titanic's* wound was in fact a series of six thin slits, some less than an inch wide. The total area of damage was only about 12 square feet—about the size of a human body, just as Edward Wilding calculated 84 years earlier.

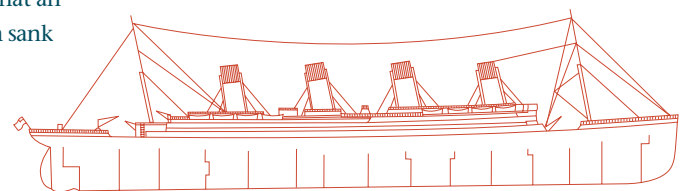

Titanic contained 16 watertight compartments.

ACTIVITY

Watertight Bulkheads

Continued from previous page...

Grade Levels:

Upper elementary, middle, high

Objective:

Students will understand the purpose of watertight bulkheads in maintaining buoyancy in ships by preserving sufficient displacement so that a damaged ship can still float.

Time:

One class period

Group Size:

Small group (3-4)

Materials:

Three 2-liter soda bottles
Knife or scissors
Dishpan
Duct tape
Weights (fishing weights, clay balls)
Timer

Procedure:

1. Cut the side off a two-liter bottle. Place it on its side with the cap in place. This will be your boat.
2. Add enough weight to the boat so that it floats evenly with the cap half covered by water.
3. Remove the cap. Time how long it takes the "boat" to sink.
4. Dry the boat and weights.
5. Cut the bottoms off two other 2-liter bottles. Insert them into the boat to create watertight bulkheads. Tape them in place.
6. Add the weights from before, spreading them evenly between the 3 compartments.
7. Remove the cap and time how long it takes the boat to sink.
8. Can you figure out a way to keep the boat floating with one compartment flooded?

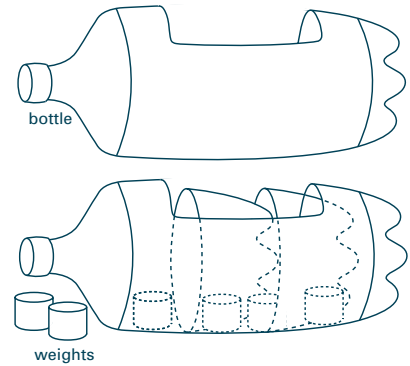

What Sank the Titanic?

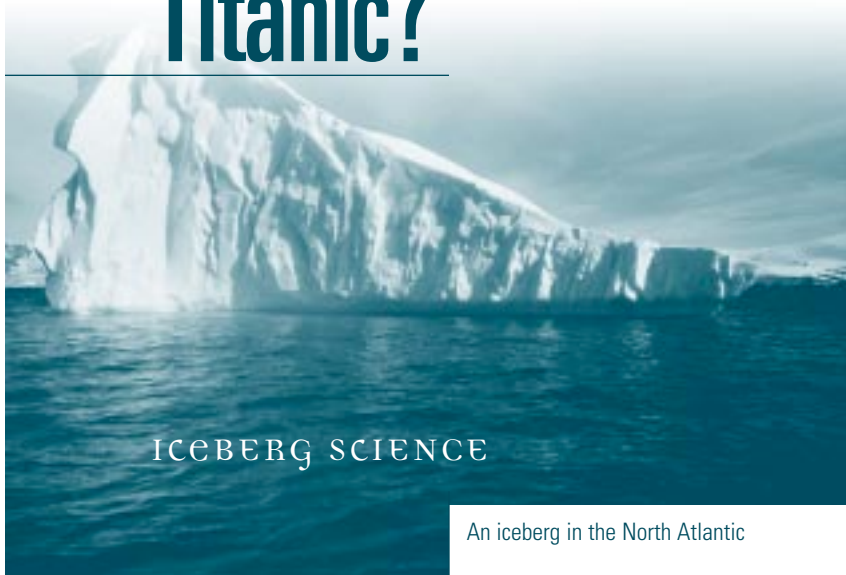

ICEBERG SCIENCE

An iceberg in the North Atlantic

Background on Icebergs

The story of the iceberg that sank *Titanic* began about 3,000 years ago. Snow fell on the ice cap of Greenland. The snow never melted. Over the course of the next forty to fifty years, it was compressed into ice and became part of a glacier—a river of ice. Due to its enormous weight, the glacier flowed toward the sea at a rate of up to sixty-five feet per day. Like the snow that formed it, the glacier ice was fresh water ice.

When the glacier reached the sea, huge chunks or slabs were weakened and broken off by the action of rising and falling tides. One of these became *Titanic's* iceberg. The iceberg slowly made its way down the coast of Greenland through Baffin Bay and the Davis Strait into the Atlantic Ocean. Most icebergs melt long before reaching the ocean. One estimate

is that of the 15,000 to 30,000 icebergs produced yearly by the glaciers of Greenland, only one percent (150 to 300) make it to the Atlantic Ocean. Once an iceberg reaches the “warm” water (32-40° F) of the Atlantic, it usually lasts only a few months. Very few icebergs are found south of the line of 48 North latitude. *Titanic's* iceberg collision took place at approximately 41° 56' degrees North latitude and 50° 14' degrees West longitude.

About 7/8ths (87%) of an iceberg is below the water line. No one is exactly sure how large *Titanic's* iceberg was, but according to eyewitness reports it was approximately 50 to 100 feet high and 200 to 400 feet long. It was tall enough to leave ice chunks on one of *Titanic's* upper decks.

Iceberg Statistics

Icebergs come in a range of sizes and shapes.

- **Growlers:**
less than 3 feet high and 16 feet long
- **Bergy Bits:**
3-13 feet (1-4m) high and 15-46 (5-14m) feet long
- **Small:**
14-50 feet (5-15m) high and 47-200 feet (15-60m) long
- **Medium:**
51-150 feet (16-45m) high and 201-400 feet (61-122m) long
- **Large:**
151-240 feet (46-75m) high and 401-670 feet (123-213m) long
- **Very Large:**
Over 240 feet (75m) high and 670 feet (214m) long



ACTIVITY

Making an Iceberg

The National Science Education Standards



Physical Science:

Properties and changes of properties in matter



Earth and Space Science:

Properties of earth materials

Grade Level:

All

Objective:

Students will realize that the majority of an iceberg is located below the surface of the water

Time:

Overnight preparation, 30 minutes in class

Group Size:

Classroom demonstration

Materials:

Balloon—9 inch or larger

Water

Salt

Freezer

Scissors

Ruler

Clear aquarium

For middle school and high school students, Wax pencil and Graph paper

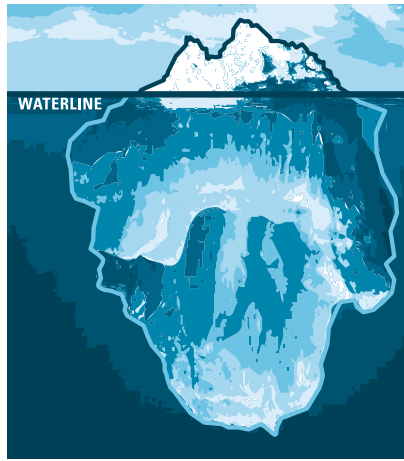

Procedure:

1. Fill a balloon with salt water. Tie the end of the balloon to seal the water inside.
2. Put the balloon inside a plastic bag and leave the bag in the freezer overnight.
3. Remove the balloon from the freezer and use the scissors to carefully cut away the balloon.
4. Put the iceberg in an aquarium filled with fresh (tap) water and observe. How much of the ice is below the water? How much is above? Use the ruler to measure how much is above and below the water line, measuring to the top and bottom of the iceberg. What percent of the iceberg is below the surface (about 87%). Where is the widest point of the iceberg—above or below the water line (below).
5. For middle school and high school students: Draw the outline of the iceberg and the water line onto the aquarium using a wax pencil. Trace the outline onto paper, copy onto graph paper and distribute to students. Have students calculate the area of the outline above and below the water line. What percent of the iceberg is above or below the water line? (approximately 87%).

ACTIVITY

Plotting Icebergs and Locations

The National Social Studies Standards



Time, Continuity, and Change:

Identify and use various sources for reconstructing the past, such as documents, letters, diaries, maps, textbooks, photos, and others.



People, Places and Environments:

Interpret, use and distinguish various representations of the earth, such as maps, globes, and photographs.



People, Places and Environments:

Use appropriate resources, data sources and geographic tools such as atlases, data bases, grid systems, charts, graphs, and maps to generate, manipulate, and interpret information.



People, Places and Environments:

Locate and distinguish among varying landforms and geographic features, such as mountains, plateaus, islands, and oceans.

Grade Level:

Upper elementary, middle, high

Objective:

Students will locate key locations in order to understand the geography of the *Titanic* story. Older students will use geographic coordinates to plot the historic positions of icebergs and of the *Titanic* during its voyage.

Time:

One class period

Group Size:

Individual

Materials:

Student worksheet, "Plotting Icebergs"
Map
Colored pencils

Procedure:

1. Have students locate key locations in *Titanic's* story. Write the names on the map.
 - Belfast, Ireland—where it was built
 - Southampton, England—where the journey began
 - Cherbourg, France—first stop
 - Queenstown, Ireland—second stop
 - West coast of Greenland—where the iceberg formed
 - Path of iceberg down the coast of Greenland, past Labrador
 - New York, USA—destination
2. Have students plot the locations of the icebergs and ice fields reported to *Titanic* on April 14 using the student worksheet and map.
3. Plot the location of *Titanic's* location per its distress call and the final location of the wreck.



Plotting Icebergs

Ice Warnings

Titanic is known to have received a total of seven ice warnings over a period of three days (April 12-14). This includes one not sent directly to her, but which she is known to have overheard and one received directly from a passing ship via blinker signal.

Throughout the day of April 14, 1912, *Titanic* received several wireless messages providing the locations of icebergs and field ice. Plot the locations of icebergs as received in the following messages. Use different colors of highlighters for the messages that indicate large areas of ice.

- A. 9am, *Caronia* to *Titanic*. "West bound steamers report bergs, growlers and field ice in 42N, from 49°- 51°W."
- B. 1:42pm, *Baltic* to *Titanic*. "Greek steamer *Athinai* reports passing icebergs and large quantities of field ice in 41° 51'N, 49° 52'...Wish you and *Titanic* all success."
- C. 1:45p.m, Message from *Amerika* to the United States Hydrographic Office, relayed by *Titanic*. "*Amerika* passed two large icebergs in 41° 27'N. 50° 8'W on April 14."
- D. 7:30pm, *Californian* to *Antillan*, overheard by *Titanic*. "42° 3'N. 49° 9'W. Three large bergs 5 miles to the southwards of us."
- E. 9:40 p.m, *Mesaba* to *Titanic*. "From *Mesaba* to *Titanic*. In latitude 42° to 41°25'N, longitude 49° to 50° 30'W saw much heavy pack ice and great number of large icebergs, also field ice, weather good, clear." This message was never sent to the bridge because the radio operator on duty was busy with passenger messages.
- F. 10:55 p.m., *Californian* stopped for the night due to heavy field ice at 42° 5'N, 50° 7'W. It attempted to inform *Titanic* of this but was cut off by *Titanic's* wireless operator.

Titanic's final positions

- T1: *Titanic's* first emergency message gave its position as 41° 46'N, 50° 14'W.
 T2: *Titanic* sent a corrected position of 41° 56'N, 49° 14'W
 T3: *Titanic* wreck site: 41° 44'N, 49° 56'W

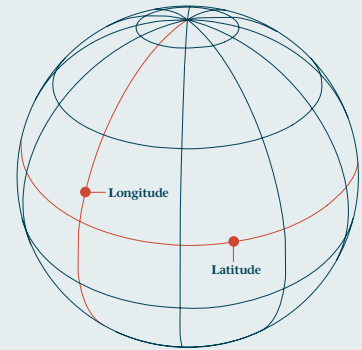

Positions on the earth are measured in terms of latitude and longitude. Latitude lines are drawn north and south of the Equator. The Equator has a latitude of 0°, while the North Pole is 90°N and the South Pole is 90°S.

Longitude is a measure of location east or west of the Prime Meridian. The Prime Meridian is 0°, the line on the opposite side of the world is 180°.

The first number in a measurement of latitude or longitude is given in degrees. If the location is more specific, the second number is given in minutes—divisions of 60, just as on a clock.

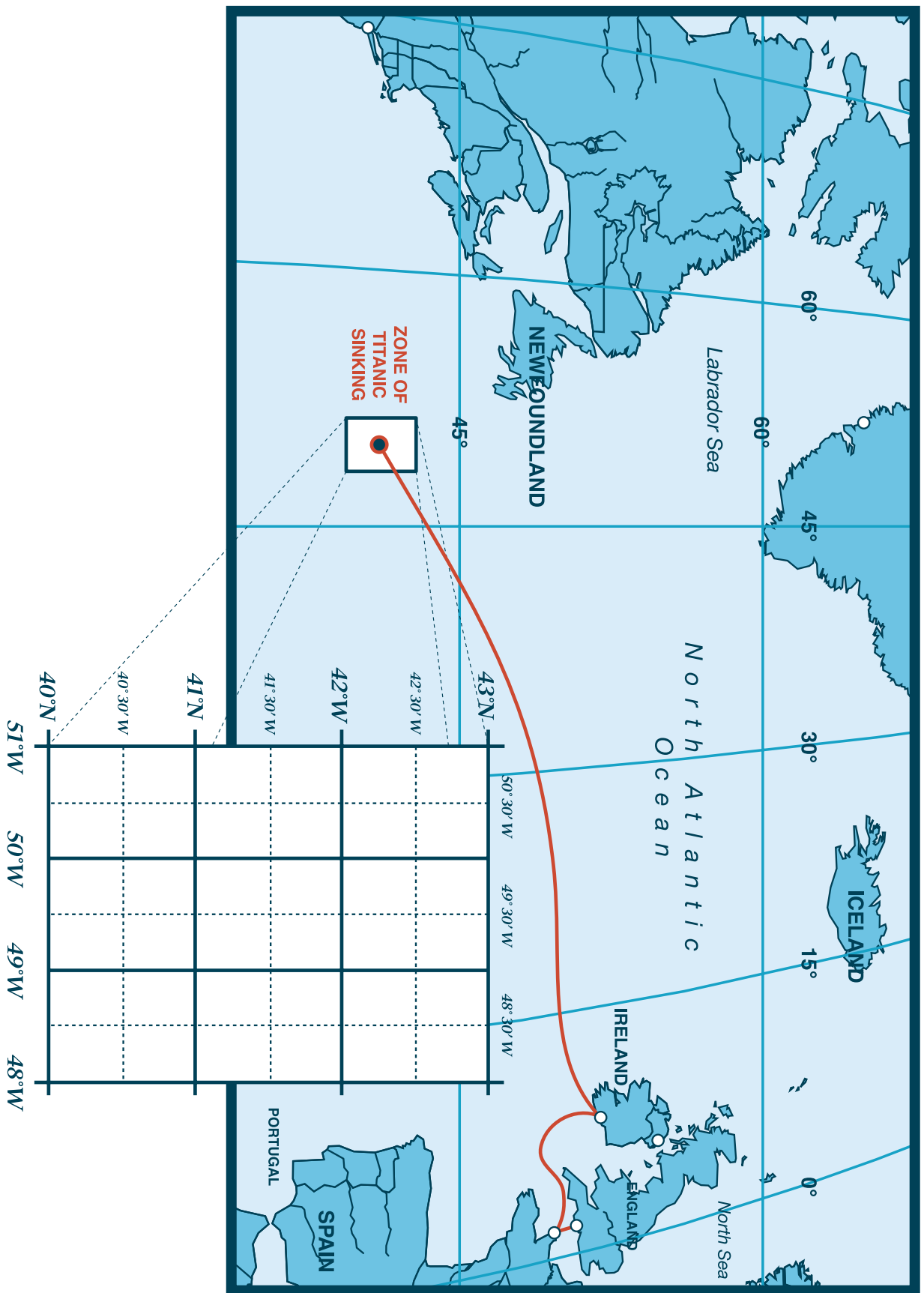



ACTIVITY

Calculating Iceberg Frequency

The National Science Education Standards

-  Earth and Space Science:
Structure of the Earth system
-  Earth and Space Science:
Earth's history
-  Science in Personal and Social Perspectives:
Natural Hazards
-  Science in Personal and Social Perspectives:
Risks and Benefits

The National Social Studies Standards

-  Time, Continuity, and Change:
Demonstrate an understanding that people in different times and places view the world differently.
-  Time, Continuity, and Change:
Use knowledge of facts and concepts drawn from history, along with elements of historical inquiry, to inform decision making about and action-taking on public issues.
-  People, Places and Environments:
Examine the interaction of human beings and their physical environment, the use of land, building of cities, and ecosystem changes in selected locales and regions.

Grade Level:

Middle, high

Objective:

1. Students will use math skills to recognize the variability of iceberg frequency in the North Atlantic.
2. Students will use risk benefit analysis to decide what they would do under similar circumstances.

Time:

One class period

Group Size:

Individual, whole class discussion

Materials:

- Worksheet, "Calculating Iceberg Frequency"
- Worksheet, "Plotting Icebergs"

Procedure:

1. Distribute a copy of the Calculating Iceberg Frequency information on the following page.
2. Have students create a bar graph showing the number of icebergs spotted in April in the years 1900 though 1911.
3. Have students calculate the average number of icebergs spotted south of 48° North latitude in the North Atlantic in April in 1900-1911.
4. Have students compare the average number of April icebergs in 1900-1911 with the number of April icebergs in 1912.
5. Have students make independent decisions about what they would have done that night. They should use both the information about the low incidence of icebergs 1900-1911 and the iceberg warnings known to have reached *Titanic's* bridge. How many students would have maintained speed? How many would have slowed? Students should justify their decision with at least two supporting points.

Information to Share Before Step 5

Why didn't Captain Smith slow the *Titanic* based on the ice warnings he received? He certainly knew that ice had been spotted near his position and in fact altered course to a more southerly route.

Captain Smith was following the practice of all captains on the North Atlantic run by maintaining his speed. People were paying good money to go across the ocean and arrive on time. A captain who slowed down merely on the basis of a warning would wreck the schedule and hurt the company's reputation for on-time performance. All captains sailed at full speed, trusting in the lookout's abilities to spot icebergs in time

to take evasive action and avoid collision. After all, the ocean is huge and there is plenty of room to maneuver.

A couple of key factors played a role in Captain Smith's decision to maintain his speed. First of all, it was common to spot individual ice-

bergs along the North Atlantic sea lane. However, *Titanic* was approaching an area of field ice where many icebergs of various sizes were located. Captain Smith failed to realize the density of the ice field he was approaching since the number of April icebergs in the area in most previous years was much smaller than in April of 1912. 1912 was an unusually heavy year for icebergs. In fact, it had the highest reported incidence of April icebergs recorded until 1970, which had 501 icebergs in April.

Another related factor was that the wireless operator on *Titanic* didn't deliver the last two ice warnings received to the bridge. A message from the ship *Mesaba*, received only hours before the collision, delineated the location of the ice field's eastern edge. Another message, in which the ship *Californian* was notifying *Titanic* that they were surrounded by ice and had stopped for the night (less than twenty miles away), was cut off by *Titanic's* wireless operator and never sent to the bridge.

Additional Resources

For information about icebergs, including a picture of the iceberg believed to have sunk *Titanic*, and a complete month by month report from 1900 to the present, check the International Ice Patrol website at www.uscg.mil/lantarea/iip

Calculating Iceberg Frequency

Iceberg Count Data South of 48° N in the North Atlantic, 1900-1912

<i>Year</i>	<i>April Total</i>	<i>Yearly Total</i>
1900	5	88
1901	4	81
1902	1	48
1903	166	802
1904	63	266
1905	373	822
1906	49	428
1907	162	635
1908	39	207
1909	134	1041
1910	34	51
1911	112	374
1912	395	1038

*Data reported by the International Ice Patrol: Iceberg Count Data South of 48° N in the North Atlantic.

One of the outcomes of the *Titanic* disaster was the creation of the **International Ice Patrol**. This organization tracks and publishes the locations of icebergs south of 48° North longitude in the North Atlantic. This information allows ships to avoid known icebergs, and from the time of its creation, no lives have been lost due to iceberg collisions.



The IIP was funded by several different countries with maritime industries but was run by the United States. It eventually became part of the US Coast Guard. Each year, the Coast Guard throws a wreath into the water at the coordinates of the *Titanic* in commemoration.

Iceberg Impact

Teacher Background

Before 1985, when *Titanic's* wreck was discovered, most people believed that the iceberg caused a 300-foot gash in the side of the ship. However, no signs of such a large opening were found in the visible parts of the wreck, but much remained buried in the mud.

In 1996, Paul Matthias of Polaris Imaging used a special piece of equipment called a sub-bottom profiler to survey the bow of the ship. The sub-bottom profiler emitted acoustic (sound) signals capable of penetrating the seabed. The signals created an acoustic image much like a medical ultrasound, allowing scientists to get images of parts of the bow that were buried under almost 20 yards of sediment.

These images show six separate openings in the hull, most of them just thin slits. Some of the slits were only as wide as a human finger. The damage totaled no more than 12 square feet, as was predicted in 1912 by Edward Wilding, a naval architect. Each of the gashes was along a riveted seam—a place where two separate plates were held together by metal rivets.

The first openings occurred just below the water line. The profiler found a minor area of damage at the very front of the ship (Point A) and two more areas of damage of 1.2 and 1.5 meters in length along a riveted seam in Cargo Hold No. 1 (Points B and C). It seems that *Titanic* must have damaged the iceberg as well, breaking away an underwater portion of the berg, because the next set of damage

to *Titanic* is lower. The sub-bottom profiler shows damage approximately 4.6 meters long between Cargo Holds Nos. 1 and 2 (Point D).

The next area of damage was even further below the water surface, about 20 feet below the water line. The sonar imaging shows large areas of damage about 10 meters in length between Cargo Holds Nos. 2 and 3 (Point E). Cargo Hold 3 took the brunt of the damage. This space filled with water the fastest at the time of the collision. The last point of contact was outside Boiler Room No. 6 (Point F).



Paul Matthias



Areas of Damage

When scientists made explorations of *Titanic's* hull, they found that there were actually six openings in the ship. Some of the slits were barely as wide as a human finger. Each of the gashes were along a riveted seam—a place where two separate steel plates were held together by iron rivets.

The first openings occurred just below the water line. It seems that *Titanic* must have damaged the iceberg as well, breaking away an underwater portion of the berg, because the next opening is lower. The next areas of damage are even further below the surface, about 20 feet below the water line.

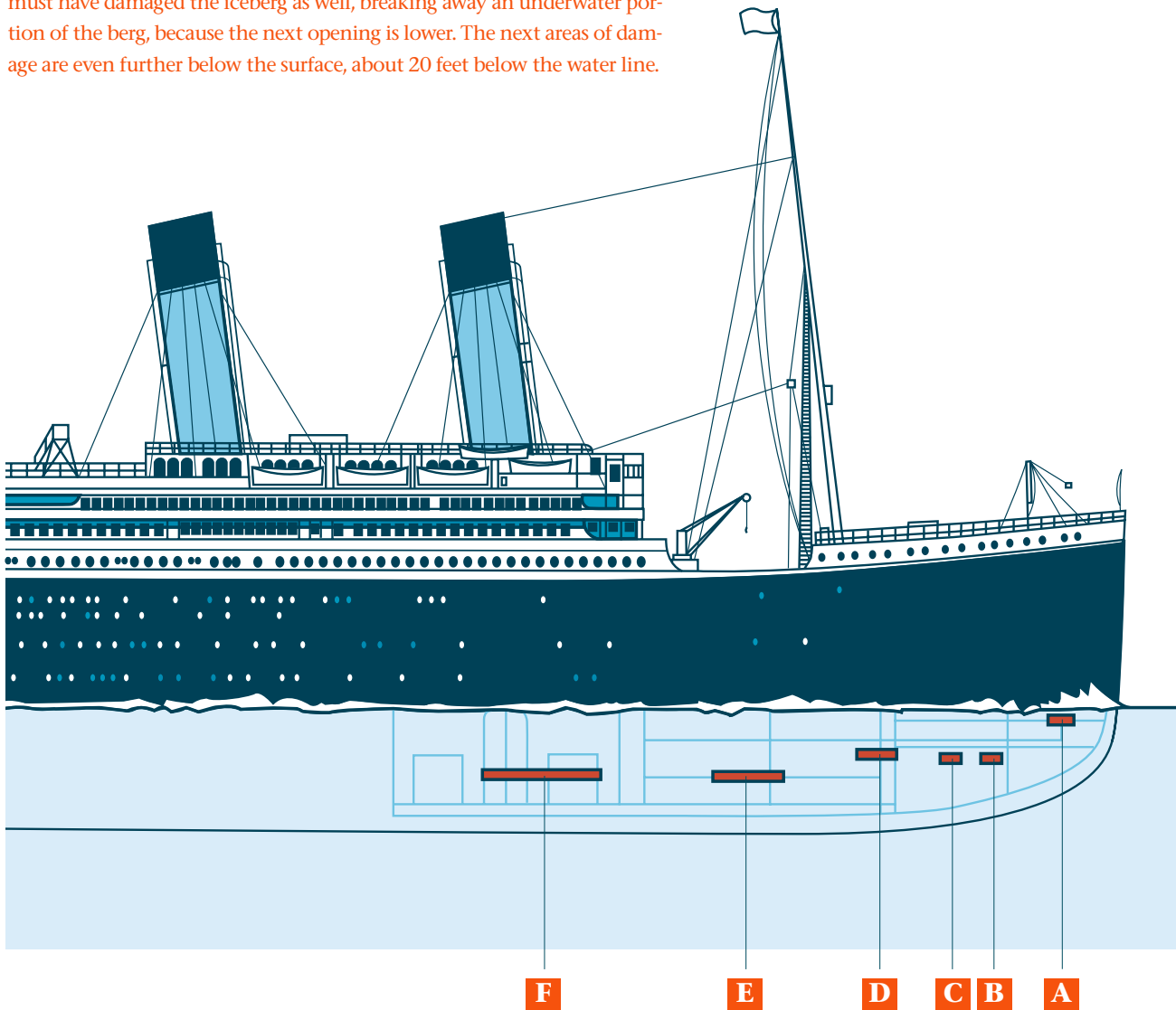

ACTIVITY

Water Pressure

The National Science Education Standards

Grade Level:

Elementary, middle, high

Objective:

Students will understand that water pressure increases quickly with depth.

Time:

One class period

Group Size:

Small group (3-4) or teacher-led demonstration

Materials:

1 gallon can or milk jug
 Something to punch holes (screwdriver, ice pick) Note: The teacher can make the holes in advance of conducting the experiment with students
 Duct tape
 Water
 Measuring Water Pressure Student Page



Physical Science:

Properties and changes of properties in matter



Earth and Space Science:

Structure of the earth system

Teacher Background

Modern naval architects used a computer model to analyze the sinking. They calculated that immediately after *Titanic* struck the iceberg, water began rushing into her hull at a rate of almost 7 tons per second. Although the holes in *Titanic* were small, the high pressure 20 feet below the water line would have forced water into the ship faster than through a fire hose.

- 11:40 pm—*Titanic* strikes the iceberg
- 12 midnight—*Titanic* has taken on 7,450 tons of water and the bow is starting to sink
- 12:40 am—One hour after impact. *Titanic* has taken on 25,000 tons of water
- 2:00 am—*Titanic* is flooded with 39,000 tons of water,

forcing the bow underwater and heaving the stern into the sky

Additional Resources

Titanic: Anatomy of a Disaster, Discovery Channel Video, 1997.
 Contact Discovery Channel School at 888-892-3484 to obtain information on additional resources.

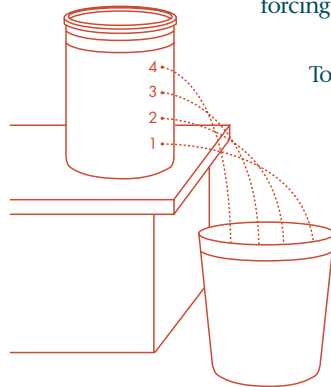

To understand how quickly water pressure increases with depth, conduct the following experiment.

Procedure:

1. Punch or drill four holes in the container.
2. Place pieces of tape over the holes.
3. Fill the container with water. Ask students to make a prediction—what will happen when the tape is removed? Will the water stay in? Will it come out of all the holes equally?
4. Place the container above a sink or dishpan.
5. Remove the tape. What do you observe? (The water will shoot out the holes. The water pressure at the top of the container is less, so the water doesn't shoot out as far. The water pressure at the bottom is greater, causing the water to shoot out further.)

The series of openings in *Titanic's* side included ones just below the water surface and some 20 feet down. Which would flood fastest due to water pressure? (The lower ones) There is an appreciable difference in the water pressure between the top and the bottom of the container, a distance of only a few inches. The difference between the pressure at the top of the ocean and twenty feet down is considerably more.

Measuring Water Pressure—Worksheet Answers

1. Water pressure increases 14.7 pounds per inch for every 33 feet or .45 pounds per foot as you descend.
2. Calculate the water pressure at 20 feet below the surface equals 14.7 lbs/in (surface pressure) + (20

feet x .45 lbs/ft) = 23.6 lbs/in

3. Calculate the water pressure at 2.5 miles below the surface 14.7 lbs/in + (5280 feet/mile x 2.5 miles x .45 lbs/ft) = 5954.7 lbs/in.... Almost 3 tons per inch!

Measuring Water Pressure

Water pressure at the surface is basically the same as the air pressure at sea level—14.7 pounds of pressure per square inch. We don't notice it because we are adapted to withstand that pressure. This pressure is measured in units called "atmospheres" which equal 14.7 pounds.

Water pressure increases rapidly with depth. At thirty-three feet below the surface, the pressure doubles to 29.4 pounds of pressure per square inch. This is like adding the weight of a heavy bowling ball to every square inch of an object at that depth. With each 33-foot increase in depth, there is an increase in water pressure equivalent to one atmosphere.

1. *For every 33 feet, water pressure increases 14.7 lbs/in.² How much does water pressure increase per foot?*
2. *Calculate the water pressure at 20 feet below the surface.*
3. *Calculate the water pressure at 2.5 miles below the surface, at the wreck site*

The *Nautilus*, the manned submersible used to explore *Titanic*, is one of only six in the world capable of operating under the pressures at this depth.

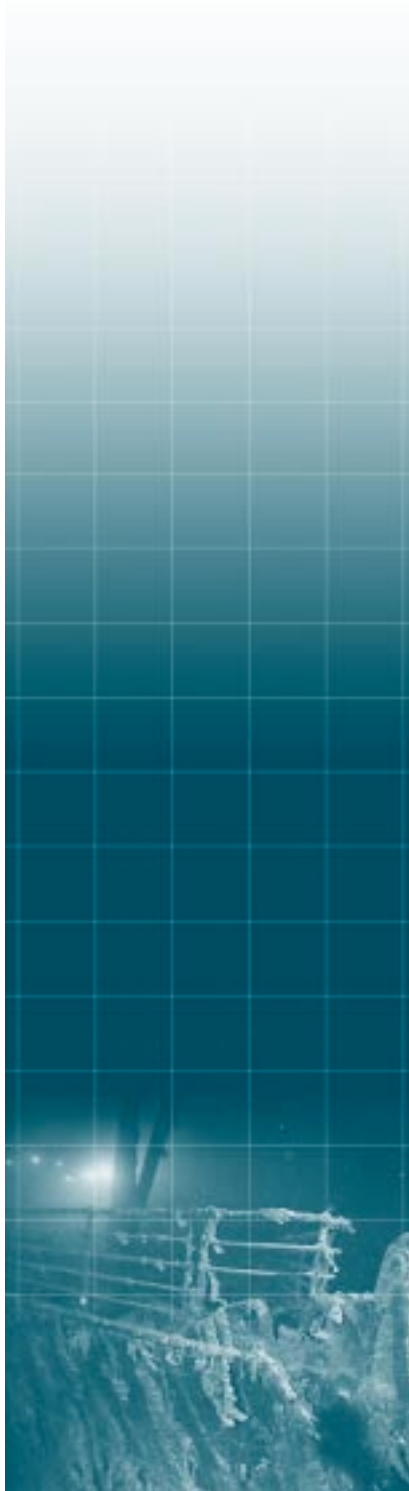

Rivet Failure

The National Science Education Standards



Science as Inquiry:

Abilities necessary to do scientific inquiry



Science as Inquiry:

Understanding about scientific inquiry



Physical Science:

Properties and changes of properties in matter



Science and Technology:

Abilities of technological design



Science and Technology:

Understandings about science and technology



History and Nature of Science:

Science as a human endeavor



Teacher Background:

One of the mysteries surrounding *Titanic* is why the ship sank so quickly. It truly was a well-designed ship, yet a glancing blow from an iceberg sank it. Other ships had struck icebergs head on and survived. So why didn't *Titanic*?

One area of inquiry has focused on the strength of the materials used in *Titanic's* construction. Most of *Titanic's* structure was made of iron in various forms. The plates that formed the ship's hull were made of steel and the rivets that held the plates together were made of wrought iron. Lines of rivets held metal plates together, much like sewing thread holds together two pieces of cloth. Investigations have shown the strength of the steel used in the hull plates to be within normal limits for 1912, but at least some of the rivets were sub-



Under construction. Notice the horizontal seams where steel plates were riveted together. The impact with the iceberg separated these seams.

standard. Dr. Tim Foecke of the National Institute of Standards is conducting an ongoing investigation of the rivets.

Pure iron is a soft metal. A soft metal will crumple or bend on impact but still hold together, while a brittle one will break apart. The rivets were supposed to be made of wrought iron, which is iron with 1 to 2 percent slag fibers running through it. Slag is a by-product of metalworking and can consist of a variety of substances (silicon, sulfur, phosphorus, aluminum, etc.) depending on its source. Slag gives iron strength but also increases its brittleness. Small amounts of slag (1-2%) make

wrought iron, which is strong but not brittle. Modern forensic investigation, led by Dr. Foecke, of rivets taken from the wreck show that the slag content in some of the rivets was very high—between 6 and 10 percent, and the slag was present in large chunks, rather than small fibers. This combination made the rivets brittle and more prone to break under stress—such as hitting an iceberg.

How did such poor quality rivets find their way onto *Titanic*? In 1912, the production of wrought iron was still an art, rather than a science. Apprentices learned by working with master craftsmen, with few of the techniques written down. It's much the same as a master chef demonstrating recipes without writing them down. Experience shows the chef how to tell when something is done by look, feel or smell—a process he/she teaches to apprentices. It was the same for iron workers in 1912. Modern iron work includes a number of scientific tests to ensure the quality of the metal produced, but in 1912, it was up to the individual iron worker to recognize when the product was ready.

In 1912, the process went like this. A "pig" of molten iron was formed. Then slag was added, the whole thing heated and tools like little rakes were drawn by hand through the melted iron to take the slag that was floating on top and draw little fibers throughout the iron as it cooled.

Dr. Foecke hypothesizes that, in the drive to make enough rivets for both *Titanic* and *Olympic*—ships that were one third larger than anything before—it's possible that the manufacturer unintentionally didn't allow sufficient time to work the wrought iron enough to evenly draw the slag into little fibers throughout the iron. The wrought iron produced would be like an incompletely mixed gravy, with lots of (microscopic) lumps. Another plausible idea is that the manufacturer needed more workers and hired some people who were not as experienced. Dr. Foecke and his colleagues are currently researching 1912 methods of rivet production to see how likely these scenarios might have been.

ACTIVITY

Rivet Failure

Continued from previous page...

Grade Level:

Middle, high

Objective:

Students will measure how differences in material composition affect the strength of a substance and will apply this knowledge to understand how defective rivets may have contributed to *Titanic's* sinking.

Time:

One or two class periods

Group Size:

Small group (3-4)

Materials:

Modeling clay (air drying)
 Angel hair pasta
 Linguini
 Gram scale (kitchen scales used by dieters often measure in grams as well as ounces)
 Ruler (in millimeters)
 Weights (pennies, fishing weights)
 Small plastic cup (from individual servings of apple sauce, yogurt, etc.)
 String

How much did the substandard rivets contribute to the tragedy? At this point, fewer than 100 rivets from *Titanic* have been studied. This is enough to know that some of them were substandard, but not enough to show whether or not they caused a problem. If only a small percentage of the 3 million rivets were bad and they were scattered randomly throughout the ship, then they probably made no difference. On the other hand, if most of the rivets were bad or if bad rivets were concentrated in certain areas, then those seams would have opened more easily and the openings extended farther, which would have caused *Titanic* to sink faster.

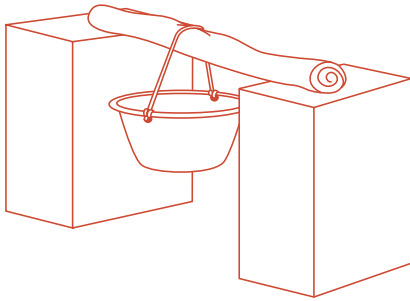
**Procedure:**

Advance preparation (can be done by the teacher or students)

1. Weigh out 10 grams of angel hair pasta and break it into small pieces.
2. Weigh out 75 grams of clay.
3. Mix the pasta pieces into the clay. Knead it until the pasta is thoroughly mixed through the clay.
4. Roll out the clay into thin rods, 5 ml in diameter and 4 inches long.

Note: Working with the amounts listed above will give enough pasta/clay mixture for several rods.

5. Repeat the above steps with the linguini.
6. Allow rods to air dry overnight.

In this experiment, the pasta is taking the part of slag and the clay represents the pure iron. The angel hair rods and the linguini rods have the same weight of pasta mixed into them, but the size of the pasta pieces is different. Ask students to predict which rods will be stronger. Why? (Students may assume that the larger, thicker pieces of linguini will add to the strength of the clay)

7. Take a small plastic cup. Punch two holes on opposite sides. Tie a length of string to both sides to form a basket.
8. Take one of the rods, place it across a gap between piles of books or between two desks. Suspend the basket from the rod.
9. Add weights to the basket until the rod breaks. Record how much weight it took to break the rod.
10. Conduct several tests with angel hair and linguini rods. Average the results. What happened? (On average, the rods with linguini will break under less weight than the rods with the angel hair. The larger linguini pieces create clumpy areas of weakness, much as the larger chunks of slag did in the inferior rivets found in *Titanic*.)

ACTIVITY

Create your Own Photomosaic

The National Science Education Standards



Science and Technology:

Abilities of technological design



Science and Technology:

Understandings about science and technology

The National Social Studies Standards



People, Places and Environments:

Use appropriate resources, data sources, and geographic tools such as atlases, data bases, grid systems, carts, graphs, and maps to generate, manipulate, and interpret information.

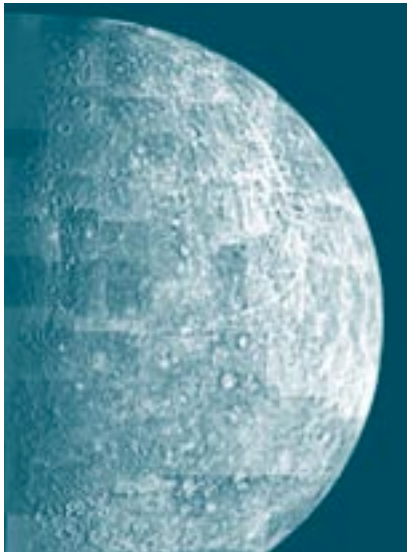

Photomosaic of the planet Mercury.

Grade Level:

Upper elementary, middle high

Objective:

Students will be able to list at least three scientific benefits of using the photomosaic technique

Estimated Time:

2 class periods

Group Size:

Small group (3-4 students)

Material:

Fixed focus 35mm camera. (The disposable cameras sold at grocery stores would work)

Film

Measuring tape

Ladder

A large object with lots of detail such as a classroom or fire truck

Teacher Background:

A photomosaic is a picture made up of smaller pictures. It's a technique often used in astronomy.

Why create a photomosaic?

Have you ever tried to take a picture of something very large? If you stand far enough away to get the entire object, it's difficult to impossible to see any of the small details in the developed picture. Photomosaics allow scientists to take many close up pictures that include lots of detail and then fit them together to create one large image of the whole. It's a useful technique for astronomers, who use it frequently when taking pictures of the Moon, other planets or even the Earth.

Scientists can also use the photomosaic technique under conditions when it is impossible to get one complete image of an object. The site of the *Titanic* wreck is one such place. Two and a half miles below the surface of the ocean is a world without light. Even the most powerful strobe lights only penetrate a few feet. The only way to get a complete overview of the condition of the *Titanic* was to take a series of photographs, each slightly overlapping, and then fit them together to create a complete image. This complete image allows scientists to identify and measure structural features that would make no sense otherwise.

To appreciate the benefits of a photomosaic, make one of your own.

Procedure:

1. Take a picture of your object from far enough away to include the whole.
2. Take a series of pictures of your object from a set distance such as four feet. If you use a disposable camera, read the instructions to determine the closest distance you can be for a clear picture. Start at the bottom left and work your way to the right, slightly overlapping the area of each image.
3. When you get to the right side, go back to the left side and stand on a ladder, just high enough to overlap the top of the image below.
4. Continue until you have photographed the entire object.
5. Develop the pictures.
6. Fit the close-ups together to make one large image. Compare it to the single photograph of the object. Look for letters, numbers or words in both. In which image is it possible to see the smallest print? (photomosaic) Which image has more detail? (photomosaic)

Additional Resources

For examples of Nasa photomosaics from space, see <http://nix.nasa.gov> and search for photomosaics

ACTIVITY

Photomosaic of Titanic

The National Science Education Standards



Science and Technology:

Abilities of technological design



Science and Technology:

Understandings about science and technology

The National Social Studies Standards



People, Places and Environments:

Use appropriate resources, data sources, and geographic tools such as atlases, data bases, grid systems, carts, graphs, and maps to generate, manipulate, and interpret information.

Grade Level:

Upper elementary, middle, high

Objective:

Students will understand how a photomosaic is used to obtain detailed information about an object by piecing together a simulation of the Titanic

Estimated Time:

One class period

Group Size:

Individual

Materials:

One copy per student (or team) of the mosaic images

Tape



Teacher Background:

In 1998, Paul Matthias of Polaris Imaging made a complete photomosaic of the wreck of the *Titanic*. Using two cameras synchronized with two strobe lights, he took over 3,000 electronic images stored on computer disks. The task of fitting them together took almost a year to complete. The information gained is

invaluable for the scientists and engineers studying the wreck. It shows that the bow of the ship hit the bottom while still mostly intact while the stern shows signs of massive implosions/explosions.

Procedure:

1. Distribute a copy of the mosaic images to each student. Have them cut them apart, marking the number of the image on the back.
2. Have the students tape the images together in order. Number one is the top left image. Number two will fit just below it, slightly overlapping. Continue fitting images together until the image doesn't seem to fit below—try putting it to the right of image #1. Continue placing images down the column. Continue until all images have been placed together.
3. Have students compare their photomosaic image to the original. Which makes more sense—one individual image or the entire photomosaic?

Note to teacher: Give younger students a copy of the original image and let them place the mosaic pieces on top of it as an aid.

Additional Resources

To access a labeled copy of the *Titanic* photomosaic, go to the RMS *Titanic* website, www.titanic-online.com

To see how scientists created the *Titanic* photomosaic, view *Titanic: Answers from the Abyss*, Discovery Channel Video, 1998. Contact Discovery Channel School at 888-892-3484 to obtain information on additional resources.





Communication



Radio as a means of communication was in its infancy in 1912. There were fewer than 100 commercial stations in the entire United States and less than 400 shipboard stations. *Titanic's* communication system was state of the art. It had the most powerful radio shipboard transmitter available with a range of 500 miles. Most other ships at the time didn't have a radio at all. Even ships with radios usually only had sets with a range of less than 200 miles.

During the first three days of the trip, *Titanic* received at least seven radio messages concerning icebergs. It also received a blinker message about ice from a ship it passed one night. *Titanic's* distress messages were heard by several ships as well as a land based station in Cape Race, Newfoundland. Her distress rockets were seen by at least one ship. Yet with all of this, it wasn't enough to avert the deaths of over 1,500 people.

ACTIVITY

Communication

or WHAT WE HAVE
HERE IS A FAILURE TO
COMMUNICATE

The National Science Education Standards



Science as Inquiry:

Abilities necessary to do scientific inquiry



Science as Inquiry:

Understanding about scientific inquiry



Science and Technology:

Abilities of technological design



Science and Technology:

Understanding about science and technology

Grade Levels:

Upper elementary, middle, high

Objective:

Students will develop alternative forms of communication for ships at sea

Time:

One period

Group Size:

Small group (2-4)

Materials:

These are suggestions only. Let your students use their imaginations!

Colored paper

Fabric

Flashlights

Crayons

Markers

Noise Makers

Worksheet, "Failure to Communicate"

Teacher Background

(to be shared with students after the activity)

Long before the invention of radio, people found ways to communicate with and between ships at sea. One of the most basic was with the use of flags. National flags quickly told ships which country other ships were from. If ships were from friendly nations, they might pull along side each other to exchange news or supplies. On the other hand, if they were at war, they might choose to run or fight. A national flag flown upside down is a sign of a ship in distress, calling for help.

Ships also used other flags or pennants to convey messages to each other. There is an entire alphabet and number system that uses flags. For most situations ships don't actually spell out entire words, they use abbreviations or single flags that have a special meaning. Ships were (and are) assigned short,

Additional Resources

International Marine Signal Flags:

<http://www.anbg.gov.au/flags/signal-flags.html>

Additional Resources

continued on the following page...

Additional Resources

For more about the *Californian* controversy: *The Californian Incident* by Leslie Harrison (date unknown)

Titanic and the Californian by Peter Padfield, 1965

"Titanic & Californian Main Page" at <http://home.earthlink.net/~hiker1217/Titanic.html>

The Ship That Stood Still by Leslie Reade. 1993.

four character combinations of flags to identify them. *Titanic's* signal flags were HVMP. These were assigned by the Registrar General of the General Register and Record Office Shipping and Seamen in Great Britain.

Since *Titanic* sank at night, it never used its signal flags, which are only useful during the day. It did, however, have other means of communicating at night. Ships carried white mast lights as well as lights on the sides—green on the starboard or right side, red on the port or left—to alert other ships to their presence and the direction in which they were traveling. In addition to its wireless radio, which was in communication with several ships in the area, *Titanic* was able to send Morse code messages using a blinker light to nearby ships. It also had rockets and flares. The rockets looked much like fireworks.

Communication, such as company identification, was handled by using

different colors and patterns of explosion. *Titanic* could identify itself as a White Star Line ship by lighting this pattern: "A green pyro light, followed by a rocket throwing 2 green stars being followed by another green pyro light." Distress rockets were always white and sent up one at a time at short intervals.



A blinker light was used to send Morse code messages at night.

Believe it or not, there was a "mystery" ship to the north of *Titanic* that night. It was close enough to be seen from *Titanic* and from its lifeboats. *Titanic's* officers estimated that this unknown ship was about five miles away. They tried communicating with it using the Morse code blinker lamp. The officers

stared at the lights of the other ship, but never felt that they received an answer.

Titanic also sent up eight distress rockets. These were white rockets that burst into stars with a loud blast.

When the *Carpathia*—the first ship to arrive after the sinking—appeared, green flares in the lifeboats were lit to guide *Carpathia* to the scene. When *Titanic* began to sink, *Carpathia* was 58 miles away. It took it four hours to get to the site where *Titanic* sank—



two hours longer than the ship was able to remain afloat.

So was there another ship within visual range of *Titanic*? And why didn't it respond?

The closest known ship was the *Californian*, which according to its calculations was about nineteen miles to the north of *Titanic* during the critical time period.

The captain of the *Californian*, Stanley Lord, decided to stop for the night due to "the dangerous proximity of ice." He instructed his wireless operator to send a message to *Titanic* stating that they were stopping. *Californian's* operator interrupted a message that *Titanic* was sending. *Titanic's* wireless operator, annoyed that this transmission was jamming his communication with Cape Race, Newfoundland, told *Californian* to "shut up and get off." After this exchange, *Californian's* sole wireless operator went to bed and never heard *Titanic's* wireless calls for assistance. Captain Lord also went to his cabin.

The crew and officers of the *Californian* did see a ship to its south. They tried to send a blinker message to the other ship, but never felt that they got a response. They did see white rockets—eight in number—go up but apparently assumed that an unknown ship was signaling *Titanic*, which they knew was somewhere to the south. No one woke the radio operator to ask him to try to find out what was going on. It wasn't until almost 6am that the captain decided to wake the wireless operator and ask him to try to contact the ship to their south. At this point, he received the news that *Titanic* had struck an iceberg and sunk during the night. In less than an hour, the *Californian* was able to move to the last known coordinates of *Titanic*, just in time to see *Carpathia* picking up the last of the survivors.

Was *Titanic's* mystery ship the *Californian*? Was *Californian's* mystery ship the *Titanic*? This is one of the most debated points in the *Titanic* story, with passionate arguments on both side of the story. At the very least, it demonstrates the problems that ships in 1912 experienced in trying to communicate without the use of the wireless.

Failure to Communicate



In 1912, wireless (radio) communication was relatively new. Many ships went to sea without it. And on ships that had it, such as *Titanic*, there was always the chance that it might break down.



Ships had sailed for thousands of years without radios. But that didn't mean that they didn't have various methods of communicating with each other.



Your task: Work with the people in your group to develop other ways of communicating across a distance. Test your methods by sending signals to your team members on the other side of the classroom.

Things to keep in mind:

1. Your signals must be clear at a distance of at least 30 feet--for a ship at sea, the distance would be measured in miles
2. You must be able to communicate some things quickly, including
 - Distress—need assistance
 - Medical problems
 - We are about to sail
 - The identity of your ship
3. Can your signals be understood at night? Or would you need another signaling method after dark?

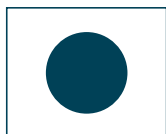

Wireless Radio and Titanic

Teacher Background

Radio waves are a part of the electromagnetic spectrum that includes radio waves, microwaves, visible light and x-rays.

Radio waves are the longest electromagnetic waves that can easily be produced and detected. The wavelengths range from a few yards to thousands of miles. AM radio waves are about 1,000 feet in length—long enough to bend around the curve of the earth. FM stations use radio waves only a few feet in wavelength. These waves do not bend around the earth, so FM stations are limited to line-

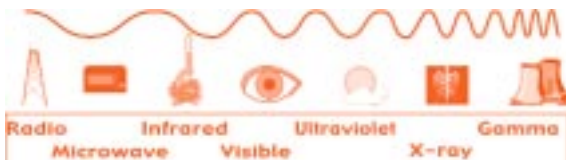

Electromagnetic spectrum

of-sight transmission. This is why FM stations fade out when you drive more than 50 miles from town. TV stations also usually transmit over the shorter wavelengths in the radio spectrum.

The signals sent by early radios were a form of controlled static. A high voltage inside a spark coil jumped across a gap, which was connected to an antenna. The spark was keyed on and off to generate the dots and dashes of Morse code. Transmitting ranges varied from as little as 600 feet with a 1/2 inch coil to around 100 miles from a kilowatt station and a 15-inch spark coil. Ships at sea with 5KW transmitters, such as the *Titanic*, could get as much as 400 miles during the day

and over 1,000 at night. During its trials, *Titanic* was able to establish communication with stations over 2,000 miles away.

The signal generated was extremely broad. A spark transmitter tuned to send a signal out on 400 meters (750 kHz) would actually generate a signal from about 250 meters (1200 kHz) to 550 meters (545 kHz). Ships, because of their restricted antenna length, were limited to frequencies between 450 and 600 meters (666 to 500 kHz). One transmitter could take up this entire spectrum, so it was important for stations to cooperate and stand by when others were transmitting.

In 1912, some sea-going ships carried wireless radios but some didn't. Most of the ships that did carry wireless only had one radio operator. When that person went to bed, the radio was turned off. Radio operators were employees of the company that owned the equipment rather than ship's officers, so they sometimes gave priority to commercial messages over ship's business or refused to communicate with ships that used a competitor's equipment.

All of these are a part of the *Titanic* story.

The *Titanic* was a rarity among ships in that it actually had two wireless operators and 24-hour a day coverage. It used equipment leased from the Marconi Company.

Titanic received iceberg warnings from several ships throughout the day of Sunday, April 12. The *Caronia*, *Noordam*, *Baltic*, *Mesaba* and other ships all report-



Photographs of John "Jack" Phillips, Senior Marconi Operator (left) and Harold Bride, Second Marconi Officer

ed icebergs and field ice. The message from *Mesaba* came in at 9:40 p.m. but was never delivered to the bridge because *Titanic* had recently come in range of the Cape Race, Newfoundland land station and the single operator on duty at that time, Jack Phillips, was too busy transmitting passenger messages.



Wireless room, similar to *Titanic*'s

At 10:30 p.m., the captain of the *Californian*, Stanley Lord, asked his radio operator to advise *Titanic* that they were surrounded by ice and were stopped. At this point, the *Californian* was located less than 20 miles from *Titanic*. The operator sent a message "Say, Old Man, we are stopped and surrounded by ice." The message was interrupted by Jack Phillips replying: "Keep out! Shut up! You're jamming my signal. I'm working Cape Race." *Titanic*'s radio operator never gave her captain the message from the *Californian*. Perhaps he hadn't listened to the content of the message before cutting it off. Perhaps he didn't realize that this was an official communication, since the *Californian*'s message was informally worded and might have been mistaken for operator to operator chitchat. Perhaps he felt the paid-for passenger messages deserved priority. No one will ever know because Jack Phillips died that night. After getting cut off, the *Californian*'s operator went to bed. When he came back on line the next morning, the first message he received reported that *Titanic* had sunk during the night.



The American inquiry into the *Titanic* disaster was handled by Michigan Senator William Alden Smith. On May 18, 1912, Senator Smith introduced a bill into the Senate. Among its provisions were: 1) ships carrying 60 passengers or more must have a wireless set with a minimum range of 100 miles; 2) wireless

sets must have an auxiliary power supply which can operate until the wireless room itself was under water or otherwise destroyed; and 3) two or more operators provide continuous service day and night. This legislation also included a provision that private stations could not use wavelengths in excess of 200 meters. It also required licenses for commercial stations, issued by the Secretary of Commerce. These licenses authorized a specific wavelength, power level, and hours of operation.

When *Titanic* struck the iceberg, one of her two radio operators felt a small jolt while the other felt nothing. When Captain Smith told them to send a call for assistance Jack Phillips began sending CQD, the code for a ship in distress. Not realizing the seriousness of the situation, Harold Bride jokingly suggested that they send SOS, the new international distress call, since it might be their only opportunity.

The *Carpathia* (58 miles away), *Birma* (100 miles away), *Mount Temple* (50 miles away), *Baltic* (300 miles away), *Virginian*, *Olympic*, *Parisian* and other ships all heard *Titanic's* emergency calls and altered course. Although *Mount Temple* was closest, it was on the other side of the ice field from *Titanic* and was unable to find a way through.

Both Phillips and Bride stayed on *Titanic* to the end and eventually made it into Collapsible Lifeboat B. Jack Phillips died but Harold Bride made it to the *Carpathia*. Although wounded, with badly frozen and crushed feet, he worked with the radio operator on the *Carpathia* to send numerous messages.

Wireless also played a role in playing a cruel trick on families waiting to hear about the disaster. There were no laws governing its use at the time and amateur and commercial stations filled the air with signals. A message came from *Cape Race* via Montreal—"All *Titanic* passengers safe. The *Virginian* towing the liner into Halifax." About two hours later, a message supposedly from the *Carpathia* said "All passengers of liner *Titanic* safely transferred to the ship and *S. S. Parisian*. Sea calm. *Titanic* being towed by Allan liner *Virginian* to port." The only problem—the *Carpathia* was a good 400 miles out to sea with a radio that could only reach 150 miles. The messages were a cruel mistake. Radio operators overheard two different messages—"Are all *Titanic's* passengers safe?" and another about the disabled tanker *Deutschland* being towed—and mistakenly put them together.

As the *Carpathia* approached land, hundreds of operators tried to establish contact with the ship. There were so many unregulated signals interfering with each other that it was impossible to distinguish one from another.

ACTIVITY

Wireless Radio

The National Science Education Standards

Grade Levels:

Upper elementary, middle, high

Objectives:

Students will produce and detect homemade radio waves similar to those used on the Titanic.

Students will try to develop communication codes and protocols for wireless transmissions.

Time:

One class period

Group Size:

Small group (2-3)

Materials

AM radio (one per team)

Insulated copper wire (18-24 AWG)—available from electronics or hardware store

Metal fork (one per team)

Masking or electrical tape

1 “C” or “D” flashlight battery (one per team)



Science as Inquiry:

Abilities necessary to do scientific inquiry



Science as Inquiry:

Understanding about scientific inquiry



Physical Science:

Transfer of energy

Teacher Background:

Wireless communication (radio) was very much in its infancy in 1912. Guglielmo Marconi, considered by most to be the inventor of the practical radio, sent his first signal over a distance of two miles in 1896—less than twenty years earlier.

In 1912, wireless communication still consisted of messages sent in Morse code—a series of dots and dashes.

As in many other things, *Titanic* was on the cutting edge of technology. It not only had a powerful wireless system, it even had two radio operators, allowing 24-hour per day coverage. During most of the voyage, even *Titanic*'s powerful transmitter/receiver was out of the range of land, so messages were few and mainly concerned navigational information, including ice warnings received from other ships.

To understand what wireless messages sounded like in 1912, students can construct a simple wireless transmitter.

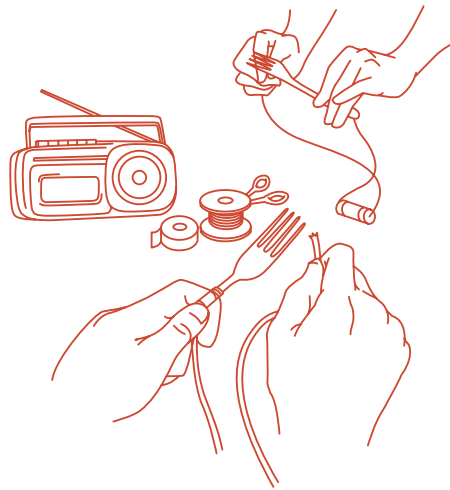

Procedure:

1. Ask students to bring in inexpensive AM radios from home.
2. Divide the class into small groups of 2-3 students. Each group should have a radio, two 25-centimeter lengths of wire, a metal fork, tape, and a battery. Note: Expose about 1 centimeter of wire from each end using a knife or wire stripper.
3. Have students securely tape the bare end of one length of wire to the end of the battery and repeat with the second wire at the other end of the battery. Wrap the free end of one of the wires tightly around the handle of the fork and tape it in place, making sure that the bare copper is touching the fork handle.
4. Ask each team to turn on its radio to the AM band and turn the dial all the way in one direction so that all they hear is static.

ACTIVITY

Wireless Radio

Continued from previous page...

5. Holding the fork close to the radio, students should stroke the bare end of the other wire across the fork's prongs. If they don't hear corresponding sounds from the radio, they should check their connections.
6. How far can the wireless transmit? (Results may vary from just a couple feet to over 20 feet) How can you increase/decrease the signal strength? (Signal strength can be modified in several ways. Tightly wrapping the wire around the fork or wrapping it more times around the fork will increase the signal. The size and strength of the battery will also make a difference) Can different teams pick up each others signals? (Probably) Have students work out ways to avoid interfering with each other's signals. (Taking turns, decreasing the signal strength)
7. Have each team work out codes for different actions, such as smiling or waving. Have one person secretly transmit the code and the others in the team respond. Were they successful? If not, why not?

International Morse Code

A • -	U • • -	Period • - - - -
B - • • •	V • • • -	Comma - - • • - -
C - • - •	W • - -	Question • • - - - • •
D - • •	X - • • -	
E •	Y - • - -	
F • • - •	Z - - • •	
G - - •		
H • • • •	1 • - - -	
I • •	2 • • - - -	
J • - - -	3 • • • - -	
K - • -	4 • • • • -	
L • - • •	5 • • • • •	
M - -	6 - • • • •	
N - •	7 - - • • •	
O - - -	8 - - - • •	
P • - - •	9 - - - - •	
Q - - • -	0 - - - - -	
R • - •		
S • • •		
T -		

Survivor Stories

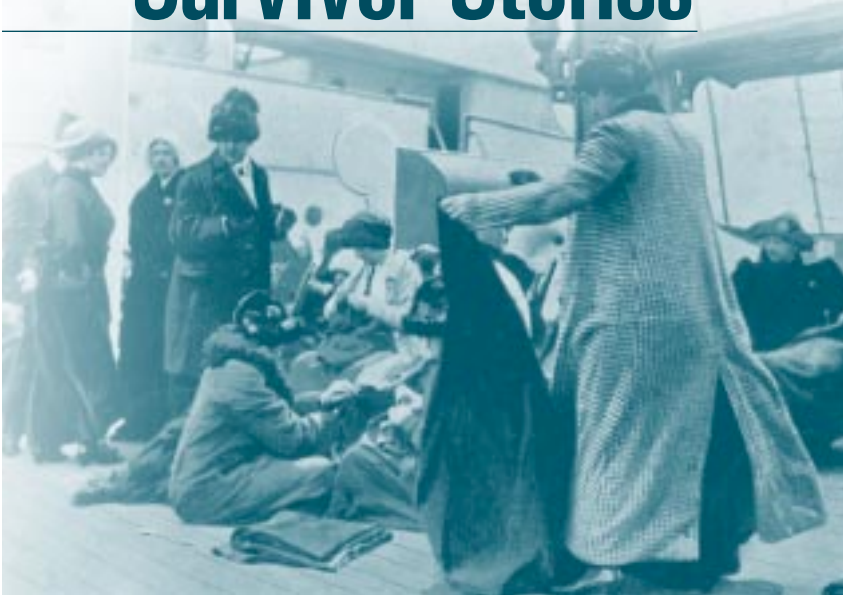

For more than 80 years, the only evidence regarding the sinking of the *Titanic* was eyewitness accounts. No physical remains were available for anyone to study in order to determine exactly what parts of the ship broke or failed, causing it to sink.

On TV trial shows, eyewitness testimony always seems so honest and dramatic. After all, the person was actually there. What could be more conclusive than an eyewitness?

In actuality, eyewitnesses often miss, forget or misinterpret important details or even lie. Stress enhances the likelihood that something will be remembered, but also limits the focus of memory. Was the robber 5'10" or 6' 2"? What color were the eyes or hair? Did you see the *Titanic* break in two or not? What was the angle of descent? What lifeboat were you on? How did you get there?

ACTIVITY

Survivors' Testimonies

The National Science Education Standards



Life Science:
Regulation and behavior

The National Social Studies Standards



Time, Continuity, and Change:
Demonstrate an understanding that different people may describe the same event or situation in diverse ways, citing reasons for the differences in views.

Grade Level:

Upper elementary, middle, high

Objective:

Students will read biographies and testimonies of *Titanic* survivors to recognize that accounts of the tragedy vary from person to person

Time:

1-2 hours of homework

Group Size:

Individual

Materials:

Copies of survivor's biographies or testimonies. Excellent sources of these include:

"Encyclopedia Titanica" at <http://www.encyclopedia-titanica.org>.
"Titanic Inquiry Project" at <http://www.titanicinquiry.org>

Due to the continuing fascination with *Titanic*, it's easy to access biographies and the original testimonies of Titanic survivors. Read some of the biographies or testimonies to find out how people survived and what happened to them after their experience on *Titanic*.

One place to start is at "Encyclopedia Titanica," www.encyclopedia-titanica.org, which contains biographies of most of the passengers and crew of *Titanic*, with direct links to contemporary newspaper articles and sometimes their testimonies at either the American or British Inquiries. In addition, the "Titanic Inquiry Project" at www.titanicinquiry.org contains the complete texts of the American and British Inquiries into the disaster, referenced by witness name.

Additional Resources

Story of the Titanic as Told by its Survivors, Dover Publications, 1960

Titanic Voices: Memories from the Fateful Voyage by Donald Hyslop, Alastair Forsyth, Sheila Jemima. 1994

Survivors' Testimonies

The National Social Studies Standards

Continued from previous page...



Time, Continuity, and Change:

Compare and contrast different stories or accounts about past events, people, places, or situations, identifying how they contribute to our understanding of the past.



Time, Continuity, and Change:

Identify and use various sources for reconstructing the past, such as documents, letters, diaries, maps, textbooks, photos, and others.

Some suggested people to research:

- Charles Lightoller, 2nd officer
- Dr. Washington Dodge
- Mrs. Ruth Dodge
- Harold Bride, Marconi radio operator
- Sir Cosmo Duff-Gordon, 1st class passenger
- Lady Lucille Duff-Gordon, 1st class passenger
- Frederick Fleet, lookout
- Robert Hichens, Quartermaster
- Masabumi Hosono, 2nd class passenger



Sir Cosmo and Lucille Duff-Gordon



Bruce Ismay

- Bruce Ismay, president of White Star Line
- Major Arthur Peuchen, 1st class passenger
- Countess of Rothes, 1st class passenger
- John Thayer Jr., 17 year old 1st class passenger
- Frederick Barrett, leading stoker
- Augustus Weikman, ship's barber

Questions to Consider:

- What acts of heroism did any of these people do or witness?
- What acts of cowardice did any of these people do or witness?
- How did these people survive?
- What incentive would a man have for lying about how he got into a lifeboat? (Some men who entered lifeboats directly from *Titanic* were viewed as cowards for the rest of their lives including Bruce Ismay and Masabumi Hosono)
- Do any of the testimonies contradict each other? (Robert Hichens and Major Peuchen)
- Do any of these testimonies talk about the same events with a different perspective (Dr. and Mrs. Washington Dodge: in his accounts, Dr. Dodge praised the courage he observed as he waited on *Titanic* for a chance to get into a lifeboat. Mrs. Dodge, who entered an early lifeboat without her husband, criticized people in the lifeboat for their lack of courage and refusal to go back to *Titanic* to save more people.)



Augustus Weikman

ACTIVITY

Estimating the Angles

The National Science Education Standards



Science as Inquiry:

Abilities necessary to do scientific inquiry



Science as Inquiry:

Understanding about scientific inquiry



Life Science:

Regulation and behavior

The National Social Studies Standards



Time, Continuity and Change:

Demonstrate an understanding that different people may describe the same event or situation in diverse ways, citing reasons for the difference in views.

Grade Level:

Upper elementary, middle, high

Objective:

Students will understand how perception influences judgement and how perception can differ from person to person based on factors such as prior experience and position.

Time:

One class period

Group Size:

Classroom demonstration

Materials:

Folding table or sheet of plywood
Protractor
Blindfolds

Additional Resources

Discovery Channel videotapes. Contact Discovery Channel School at 888-892-3484 to obtain information on additional resources.

Testimonies of Charles Lightoller, John Thayer Jr.

One of the puzzling aspects of *Titanic's* sinking has been the variety of different angles that people claim for the ship as it sank. Some people say it was perpendicular to the sea (90°) while others say it was 45° or 60° . The latest computer models put the angle of descent at much less (12°). With a ship the size of *Titanic*, even this slight angle of descent would be enough to raise her propellers out of the water. It also agrees with Charles Lightoller's testimony that he swam from the bridge area of *Titanic* to her crow's nest. For the bridge and crow's nest to be at the same level, the angle would be around 12° .

Procedure:

1. Ask for 5 volunteers. Send them out of the room.
2. Position the table so that it is touching the floor at an angle. Use the protractor to measure the angle.
3. Blindfold the volunteers, bring them in and have them lie down in varying positions around the table.
4. Remove the blind folds and tell them to observe the table and write down their estimates as to the angle.

5. Compare their answers to the actual measurement. How accurate were they?

What factors might affect their success in accurately determining the angle? (Prior experience in estimating angles, position—people directly facing the front or back will have difficulty because of the lack of perspective.)

Ask students what factors would affect *Titanic* survivor's memories of the angle of descent (inexperience in estimating angles, the excitement of the moment, location—if they were in a lifeboat floating under the ship's propellers vs to the side of the ship).

Sketches based on the memory of John (Jack) Thayer, a 17-year-old survivor, as drawn by L.D. Skidmore, a passenger on the *Carpathia*.

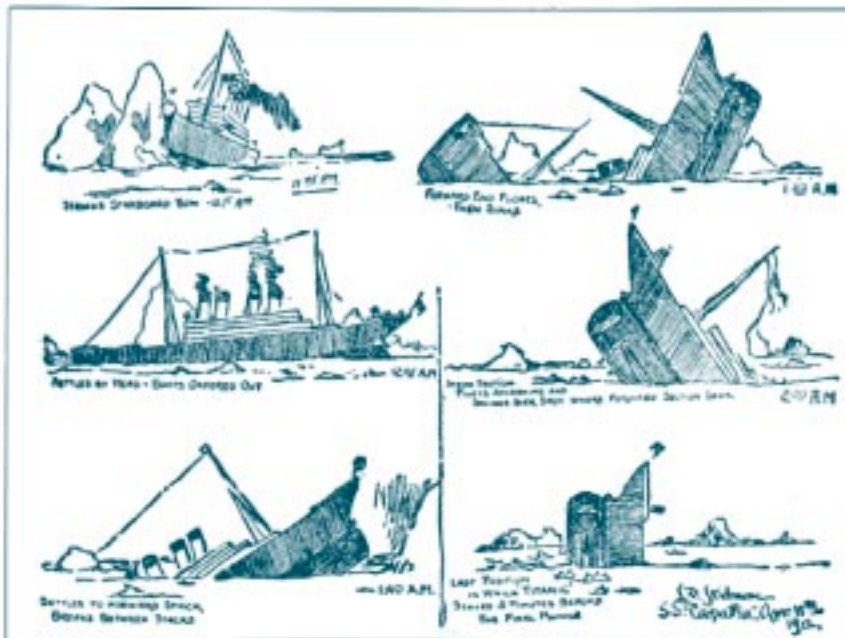

ACTIVITY

Testing Eyewitness Memory

The National Science Education Standards



Science as Inquiry:

Abilities necessary to do scientific inquiry



Science as Inquiry:

Understanding about scientific inquiry



Life Science:

Regulation and behavior

The National Social Studies Standards



Time, Continuity and Change:

Demonstrate an understanding that different people may describe the same event or situation in diverse ways, citing reasons for the difference in views.

Teacher Background:

These two procedures reveal different aspects of memory. In the first variation, the element of surprise may make students pay more attention. Research has shown that stress, leading to higher levels of attention, increases the accuracy of memory but decreases the amount of information that witnesses remember. In other words, witnesses under stress tend to experience tunnel vision. What they remember of the things they focus on may be very accurate, but they can't see the big picture.

Grade Level:

All

Objective:

Students will understand how eyewitness testimony may not be completely accurate

Materials:

Odd clothing, noisemakers, objects
1-3 assistants

The second procedure tests the suggestibility of memory. Students have plenty of time to accurately observe the scene, but when asked about something not in the scene, they will try to please the questioner by remembering something that wasn't there.

Titanic survivors probably experienced both of these. Certainly the sinking of the ship was stressful enough for people to pay attention, but that same stress caused them to focus on smaller pieces of the event. When asked about something that they probably witnessed, they might not remember it or might subconsciously manufacture a memory.

Procedure, variation 1

1. In secret, dress an assistant (another teacher or school staffer) in a distinctive set of clothing. Provide the person with a noise maker(s) or other objects.
2. While you are conducting your class as normal, have the assistant make a short surprise appearance—perhaps running through the class.
3. After the assistant has left the room, give each student a sheet of paper and ask them to record what just happened. They should try to be as detailed as possible, including information about what the person looked like, dressed, and acted.
4. Collect the results and compare them to the actual assistant.

Procedure, variation 2:

1. Have two assistants act out a scene such as eating a picnic lunch. Let the class observe for 3-5 minutes.
2. Have the assistants leave the room.
3. Ask students questions about the scene and have them write down their answers on a sheet of paper. Include both questions that really could have been observed (how many people were there) but also have questions about objects not in the scene (what color was Joe's hat).
4. Compare results. Many people will vividly remember the hat, even though it wasn't actually present, just because a question was asked about it.

Ask students what these experiments show about the memory of *Titanic* survivors? (They could be incomplete, inaccurate.) How can we improve our confidence in an eyewitness memory? (Compare to other accounts, try to ask open-ended questions that don't influence the witness, evaluate whether or not the witnesses prior experiences would make them able to make accurate observations about the circumstance)

ACTIVITY

Could More Have Been Saved?

The National Science Education Standards



Science as Inquiry:

Abilities necessary to do scientific inquiry



Science and Technology:

Abilities of technological design



Science in Personal and Social Perspectives:

Risks and benefits



Science in Personal and Social Perspectives:

Science and technology in society

The National Social Studies Standards



Time, Continuity, and Change:

Use knowledge of facts and concepts drawn from history, along with elements of historical inquiry, to inform decision making about and action-taking on public issues.



People, Places, and Environments:

Propose, compare, and evaluate alternative uses of land and resources in communities, regions, nations, and the world.

Grade Level:

Upper elementary, middle school, and high school

Objective:

Students will creatively problem solve to develop means which might have increased survivorship during the Titanic disaster.

Time:

One class period or homework

Group Size:

Individual or small group

Materials:

Worksheet, "Could More Have Been Saved"

Procedure:

Distribute one copy per student of "Could More Have Been Saved" Worksheet.

Allow students one class period or time at home to brainstorm additional ways for people to have been saved.

Share class results as well as historical results.

Going further (optional)

Have students examine actual deck plans and cargo lists to determine what was actually on *Titanic*. This information can be found in many books written about *Titanic* and on *Titanic* websites. See the "Additional Resources" for a few suggestions.

Historical Outcome, to be shared after the activity:

One of the simplest ways to increase the number of people saved would have been to fully load the lifeboats. Taking this step alone could have saved nearly 500 more people. A number of reasons exist to explain why this wasn't done originally. People were reluctant to board some of the first lifeboats launched, refusing to believe the seriousness of the problem. Women refused to be separated from their husbands and sons. The crew was afraid at first to load the boats to capacity, fearing that the davits wouldn't support the weight of the loaded boats as they were



lowered down the sides. It wasn't until later that one of the *Titanic's* designers told them that the davits had been designed to handle fully loaded lifeboats. The early lifeboats were instructed to row toward lights apparently from a ship that could be seen in the distance. If they could have reached this mystery ship, they might have been able to summon help for the rest of the passengers. Even when Captain Smith used a megaphone to call for lifeboats to come back toward *Titanic* to pick up more people, none did for fear of getting pulled under when the ship went down.

Additional Resources

Titanic: Triumph and Tragedy by John P. Eaton and Charles A. Haas. W. W. Norton & Company, Inc., New York, 1994.

Encyclopedia Titanica.
www.encyclopedia-titanica.org/

Could More Have Been Saved?

Continued from previous page...

Very few of the people who died actually drowned. Most of the people on board were wearing life preservers that were designed to keep the head out of the water. The major cause of death was hypothermia. None of the lifeboats in the area returned to the scene until after the screaming stopped. A few people were able to locate floating objects buoyant enough to support them until they were picked up by lifeboats that returned to the scene after *Titanic* disappeared.



Charles Joughin (left), chief baker, threw at least 50 deck chairs overboard. He eventually survived by clinging to an overturned lifeboat.

Augustus Weikman (right), the ship's barber, clung to 3 chairs until a lifeboat picked him up.



A Chinese sailor tied himself to a door and was picked up by a lifeboat.

Passengers on board the *Bremen*, a ship that passed the site of the sinking a week later, reported the following:

"New York, Wednesday. The North German liner Bremen, which arrived here (New York) this morning, reports having passed seven icebergs on Saturday last (4/19) in the locality where the Titanic disaster occurred. Many bodies were seen floating in the water around the spot where the liner sank. All bore lifebelts. Some of them are described as clasping the bodies of children, and others as still gripping deck chairs and other objects. The officers of the Bremen estimated that in one group there were two hundred corpses."

—London Daily Sketch, Thursday, April 25, 1912.

Could More Have Been Saved?

Your Task:

Imagine that you are the captain of the *Titanic*. You've just been told that the ship is going to sink in about two hours. You know that you have only enough lifeboats for about half of the people on board. Is there anything else that you can do to maximize the number of people saved? The air temperature is 33° F, and the water temperature is 27° F. Prolonged exposure to the cold leads to a condition called hypothermia, which can be deadly.



Consider:

What materials might be on the *Titanic* that could float or be made to float?

What other resources are available nearby?

Could you increase the capacity of the existing lifeboats?

Hypothermia caused by frigid water is the greatest danger. Try to keep people dry.

Background:

When *Titanic* was full, it was capable of carrying 3,295 passengers and crew. Fortunately, *Titanic* sailed on its maiden voyage with only 2,228 people.

British Board of Trade regulations at the time only required enough lifeboats on a ship of her size for approximately 960 people. *Titanic* actually exceeded these requirements, by putting to sea with twenty lifeboats capable of holding a maximum of 1,178 passengers and crew.

Only 705 people were saved. If *Titanic* had been filled to capacity, it would have taken 63 lifeboats to evacuate everyone.

What is hypothermia?

A body temperature of less than 96° F, only a couple of degrees below the norm of 98.6° F, can cause an irregular heartbeat leading to heart failure and death. A body can cool down 25 times faster in cold water than in air. Water temperature, body size, amount of body fat and movement in the water all plays a part in cold water survival.

Water Temperature	Exhaustion or Unconsciousness	
	Expected Survival Time	Expected Survival Time
32.5°F	<15 min.	<15-45 min
32.5°-40°	15-30 min.	30-90 min
40°-50°	30-60 min.	1-3 hrs
50°-60°	1-2 hrs	1-6 hrs
60°-70°	2-7 hrs	2-40 hrs
70°-80°	3-12 hrs	3 hrs +
Over 80°	Indefinite	Indefinite

Chances for recovery depend on how long a person was exposed to the cold and his/her general health. If body temperature has not dropped below 90° F, chances for a total recovery are usually good. If body temperature has fallen to between 80° F and 90° F, most people will recover, but some lasting damage is likely. If the temperature goes under 80°F, most victims will not survive.

The Fate of Titanic and its Artifacts



Since its sinking, *Titanic* and its contents have existed in an environment drastically different than found on the surface of the world. Salt water, high pressure, acidic sediments have all taken their toll. The ship itself is disappearing beneath tons of rust. Artifacts brought to the surface deteriorate quickly unless immediate steps are taken to preserve them.

ACTIVITY

Rust in the Classroom

The National Science Education Standards

Grade Level:

Elementary, middle, high

Objective:

Students will observe how the formation of rust varies under different conditions.

Time:

15 minutes to set up, several days to complete

Grouping:

Small group or class demonstration

Materials:

Uncoated iron nails (hardware store)
Water
Salt
Sugar
Small containers



Physical Science:

Properties of objects and materials.

Teacher Background:

The *Titanic* is covered with rust. Rust is the common name for iron oxide (Fe_2O_3) formed when iron corrodes. Actually, corrosion is just the process by which a refined metal such as steel goes back to its natural state.

The same properties that make iron a good conductor of electricity (free electrons) cause it to corrode quickly in a moist environment. Iron and oxygen (found in air and water) exchange electrons more easily in the presence of water. Salt water provides an even better environment for corrosion.

To observe the process of rusting in the classroom, do the following:

Procedure:

1. Fill two small containers with water. To one, add a teaspoon of salt.
2. Put a nail into each container.
3. Observe the nails in each of the containers daily for a week. Which nail shows signs of rust first? (Teacher note: it should be the nail with salt that accelerates the corrosion of the iron nail. If however, the plain tap water quickly shows signs of the nail rusting then maybe there are rust problems in the hot water heater and pipes!)

ACTIVITY

Rust on the Titanic

The National Science Education Standards

Grade Level:

Middle, high

Objective:

Students will discover that the action of microbes can be detected using photographic slide film.

Time:

Class period to set up, one week to run

Group Size:

Small group (3-4)

Materials:

Slide film

Aida cloth (available at stitching/craft shops)

Needle

Thread

Soil

Aquarium water

Microscope or slide projector



Science as Inquiry:

Abilities to do scientific inquiry



Science as Inquiry:

Understanding about scientific inquiry



Physical Science:

Properties and changes of properties in matter



Life Science:

Structure and function in living systems



Life Science:

Diversity and adaptations of organisms

Teacher Background:

Since iron naturally corrodes in salt water, no one was surprised to see signs of rust on the *Titanic*. Much of the rust was in the form of reddish-brown stalactites, which scientists dubbed “rusticles”. No one paid too much attention to the rusticles, or the rust in general until the gymnasium roof, intact in 1994, caved in, along with the canopy of the crow’s nest. Scientists soon realized that the structural integrity of the *Titanic* was weakening over time. Could the rusticles provide information about the cause and rate of the deterioration?



As the rusticles were considered, scientists noticed a resemblance between them and growths caused by iron related bacteria that plug pipes, screens and pumps in water wells. Could the rusticles be the result of bacteria that were actually eating the *Titanic*? Or was the rusticle simply a physical change brought on by the high pressure, high salinity (salt) environment?



Dr. Roy Cullimore and his assistant, Lori Johnston

Dr. Roy Cullimore, a microbiologist specializing in iron-related bacteria in water wells, joined

the 1996 and 1998 expedition teams. His job was to determine whether there were bacteria present on the *Titanic* and if there were, was there any way to determine how fast they were destroying the ship.

To determine whether there were bacteria present, Dr. Cullimore performed a simple test. He took unexposed color slide film and developed it.

He then put the black slides into bags made from Aida cloth. Aida cloth is woven with evenly spaced small holes, providing a way for the bacteria to enter the bag. If bacteria were present on the *Titanic*, they would consume the protein emulsion on the slide film. The colors released would stain the Aida cloth, signaling that it was time to pick up the experiment. The slides could be viewed under a microscope or by using a slide

Additional Resources

Dr. Roy Cullimore's research on *Titanic*, including projections about how long the ship will remain intact, are described on his website: www.dbi.sk.ca

Titanic: Anatomy of a Disaster, Discovery Channel Video, 1997. Contact Discovery Channel School at 888-892-3484 to obtain information on additional resources.

Rust on the Titanic

Continued from previous page...



A section of *Titanic* on the ocean floor, covered with rusticles

projector. Bacterial activity would show as complexes of colored patterns caused by the microbes eating away the gelatin.

You can conduct the same experiment.

Procedure:

1. Purchase a roll of slide film and get it developed immediately. The resulting slides will be black.
2. Create little bags out of the Aida cloth large enough to hold one slide. The holes in the Aida cloth provide the microbes with a way to get to the slide film while still protecting it from debris and damage.
3. Bury some of the bagged slides just under the surface of soil that is kept damp but not soaked. Suspend other bags in aquarium water. Note: The silver salts in the slide film might harm fish. Instead of using an actual aquarium, move some of the aquarium water and bottom gravel to a new container.
4. Remove one slide per day and examine it. Bacterial growth will show as branching tunnels etched onto the slide, visible with the naked eye. Deeper tunnels can be seen using the microscope or slide projector. Note: Bacterial growth typically slows during colder weather. If this experiment is done when daytime highs are below sixty degrees, it may take a few days before results can be seen.

Results from the Titanic

When Dr. Cullimore collected his samples after twenty days, he was able to see complex tunnels and patterns caused by the bacteria as they ate their way through the protein on the slide while avoiding the silver salts. This proved that bacteria were alive and well on *Titanic*.



To determine just what kinds of bacteria were present, Dr. Cullimore collected samples of rusticles, which he took back to his laboratory. So far, he has found that the rusticles are extremely complex structures, inhabited and created by a variety of different microbes that include iron-related bacteria, sulfate-reducing bacteria and fungi. Iron related bacteria (IRB) live on organic matter present in water. As they grow, they create a coating in which they deposit iron oxides, giving the growths an orange to brown to black color.

The interior of the rusticle contains a complex system of channels that move water throughout. When dried, a rusticle typically has an iron content of 20-30 percent.

Titanic began as iron ore that was mined, refined into steel and shaped into a ship. The rusticles are returning it to iron ore.

Rusticles are currently attached to over 80% of *Titanic's* hull. Preliminary calculations indicate that as of 1996 the mass of rusticles may weigh 650 tons, which would include as much as 175 tons of iron. Dr. Cullimore and others calculated that the internal minimum surface area of the rusticles was almost 6,280 square miles.

Eventually the rusticles will mine enough of the iron out of *Titanic's* structure that the ship will collapse. When that will occur is still under study. Estimates range from 15 to 450 years.

ACTIVITY

Artifact Conservation

The National Science Education Standards



Science as Inquiry:

Abilities to do scientific inquiry

Science as Inquiry:

Understanding about scientific inquiry



Physical Science:

Properties and changes of properties in matter



Science and Technology:

Abilities of technological design

Science and Technology:

Understanding about science and technology

The National Social Studies Standards



Time, Continuity, and Change:

Identify and use various sources for reconstructing the past, such as documents, letters, diaries, maps, textbooks, photos, and others.

Grade Level:

Upper elementary, middle, high

Objective:

Students will work with damaged objects and generate ideas about how to conserve and restore them.

Time:

One class period

Group Size:

Individual or small group

Materials:

Salt water

Construction paper or photographs

Containers such as bowls or jars

Paper towels

White paper

Paper clips

Pencils

Tape

Glue

Staplers

Teacher Background:

The environmental conditions at the *Titanic* provide a mixed situation for preserving artifacts. On the good side, the combination of no light, little oxygen and near freezing temperatures aid in preserving objects. On the negative side: the bottom silt is acidic, the pressure is 400 times greater than at the surface and the electrochemical activity of sea water along with deep sea microorganisms that metabolize metal have stained and corroded many metal objects.

All recovered objects must be treated immediately after they are exposed to air. The surface of some metal objects made of iron can explode, fizzle or steam when exposed to the corrosive oxygen in air. When objects soaked in sea water begin to dry out, the salts that have embedded them crystallize, taking up more space and causing minute fractures that can rupture the glazes on ceramics. Wood, leather, paper and other organic objects can also deteriorate quickly if allowed to dry, since bacteria and fungi grow more quickly when items are exposed to light and oxygen.

As soon as artifacts are recovered from the sea, they are stabilized for shipment. After careful cleaning with a soft brush, they are placed in foam-lined tubs of water and then transferred to a conservation laboratory on land.

Once the objects arrive at the lab, they are washed repeatedly in deionized water to leach out salts from the surface. Salts and other impurities that have accumulated deep within an object require a variety of special treatments, based on the material. Electrolysis is effective for restoring metal objects. Conservators place metal objects in chemical baths, wiring them to a negative battery terminal, and covering them with a metal cage connected to a positive terminal. The current pulls the negative ions and salt out of the artifact, effectively removing the corrosion. Electric currents can remove salts from paper, leather and wood as well. These materials are also treated with chemicals to remove rust and fumigated if they appear to be contaminated with mold. Polyethylene glycol, a water-soluble wax, is injected into wood and leather objects to fill the spaces left by the water as it evaporates.

Nobody expected that paper would have survived so long at the bottom of the ocean, but the *Titanic* is a treasure trove of sheet music, personal letters, postcards

Additional Resources

Titanic: Anatomy of a Disaster, Discovery Channel Video, 1997. Contact Discovery Channel School at 888-892-3484 to obtain information on additional resources.



Rivet from the *Titanic*

Artifact Conservation

The National Science Education Standards

and even paper money. Papers are conserved by freeze-drying, which removes all the water. They are then treated to protect them against mold and are resized to restore their shape. Papers are stored in the dark, with temperature and humidity strictly regulated. Along with conserving an object for the future comes the question of whether or not it should be restored to its original condition. The conservators working on the *Titanic* artifacts have chosen to do a minimum amount of restoration, believing that the story of the wreck is best told by allowing the objects to show the signs of their internment two and a half miles below the surface of the ocean. The immense pressure at that depth has crushed hollow-handled knives and forks and pushed corks into wine bottles.

Procedure:

1. Crumple and tear a photograph. Note: the use of photographs in this activity is more realistic, but only use photos that can be safely sacrificed. If you cannot find any sacrificial photos, use a piece of notebook paper. Tell the class that they are museum conservators and that this photograph is an important artifact, found on the *Titanic*. As museum conservators (scientists who work to preserve artifacts) they have been asked to conserve and restore the artifact. How would they go about this task?
2. Define conservation and restoration. Conserving an object means to protect it from being damaged any more than it already is. Restoring an object means to make it look as close to its original condition as possible.
3. Explain that the first job is to conserve the artifact. Anything that is done to it at this point might damage it further. Question: how could they damage the object just by touching it (dirt and oil from their hands, accidentally tear it). Ask students to brainstorm ways they could handle the photo so that it will not be further harmed (answers will vary but could include wearing gloves, washing hands, using tweezers).
4. The next task is to restore the artifact. What did the photograph look like in its original condition? Ask students to brainstorm how they could restore the object so that it would be close to its original condition. How could they get rid of the wrinkles? How could they get it to lie flat? How could they put it back together?
5. Divide the class into groups of 2-3 students. Each group will receive the following materials:
 - Small pieces of a photograph (or construction paper) soaking in a container of cold salt water.
 - Sheet of plain white paper, randomly torn into 3-5 pieces
 - Large paper clip, bent and twisted
 - Pencil, broken in half
 - Tape, glue, stapler, paper towels to dry the wet paper
6. Tell the students that these are important artifacts found at the wreckage site of the *Titanic*. For each object, students will:
 - Make a plan to conserve the objects.
 - Decide what the object originally looked like.
 - Make a plan to restore the object
 - Use tape, glue, staples or some other method to restore the object so that it looks as close to new as possible.

Are there any objects in which the goal of conservation may be in conflict with the goal of restoration (the paper clip may break). Do you think that this problem occurs for scientists? (Frequently! The conservators for *Titanic* artifacts have decided to only restore them enough to conserve them. They feel that the wear and tear that the objects demonstrate tell people an important part of the *Titanic* story.)

Photographic Credits

Page 3 - Ulster Folk and Transport Museum/Harland & Wolff Photographic Collection
Page 4, top left - Ulster Folk and Transport Museum/Harland & Wolff Photographic Collection
Page 8, top - Ulster Folk and Transport Museum/Harland & Wolff Photographic Collection
Page 10 - U.S. Coast Guard
Page 17, middle - RMS Titanic, Inc.
Page 17, bottom - U.S. Coast Guard
Page 21, top - Ulster Folk and Transport Museum/Harland & Wolff Photographic Collection
Page 23 - NASA
Page 24 - RMS Titanic, Inc.
Page 29 - NMPFT/Science & Society Picture Library
Page 32, top - NMPFT/Science & Society Picture Library
Page 32, bottom - Charles A. Haas/John P. Eaton Photograph Collection
Page 36, top - Mary Evans Picture Library
Page 37 - Charles A. Haas/John P. Eaton Photograph Collection
Page 38 - Mary Evans Picture Library
Page 40 - Mary Evans Picture Library
Page 41 - Charles A. Haas/John P. Eaton Photograph Collection
Page 43, top - RMS Titanic, Inc.
Page 45, middle left - RMS Titanic, Inc.

Illustrations by Mike Cao, Jim Glass and Edward Alton